

# Prayas JEE (2025)

## Physics

### Capacitor

DPP: 2

**Q1** Three initially uncharged capacitors are connected to a battery of 10 V in parallel combination. Find out the following?

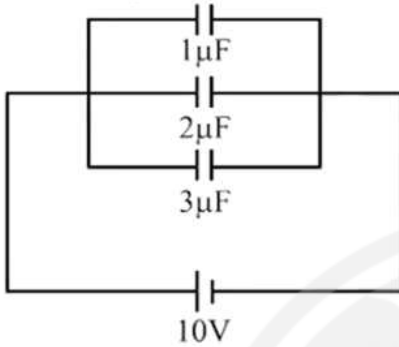

- (i) Charge flow from the battery.
- (ii) Total energy stored in the capacitors.
- (iii) Heat produced in the circuit.
- (iv) Potential energy in the  $3\mu\text{F}$  capacitor.

**Q2** Two capacitors of capacitances  $C_1 = 6\mu\text{F}$  and  $C_2 = 3\mu\text{F}$  are connected in series across a cell of emf 18 V. Calculate

- (i) The equivalent capacitance,
- (ii) The potential difference across each capacitor,
- (iii) The charge on each capacitor.

**Q3** In the circuit shown the capacitors are  $C_1 = 15\mu\text{F}$ ;  $C_2 = 10\mu\text{F}$  and  $C_3 = 25\mu\text{F}$ . Find

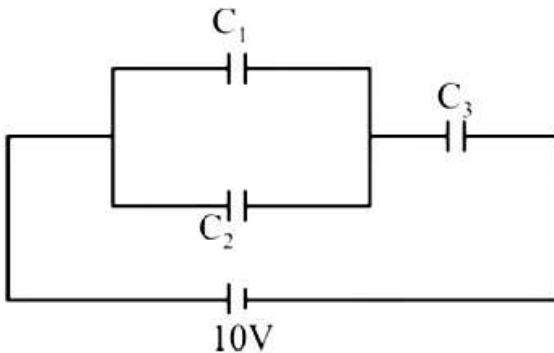

- (i) The equivalent capacitance of the circuit,
- (ii) The charge on each capacitor and

(iii) The potential difference across each capacitor

**Q4** A parallel plate capacitor is made by stacking  $n$  equally spaced plates, connected alternately. If the capacitance between any two plates is  $C$  then the resultant capacitor is.

- (A)  $C$
- (B)  $nC$
- (C)  $(n - 1)C$
- (D)  $(n + 1)C$

**Q5** Seven capacitors each of capacity  $2\mu\text{F}$  are to be so connected to have a total capacity  $\frac{10}{11}\mu\text{F}$ . Which will be the necessary figure as shown ?

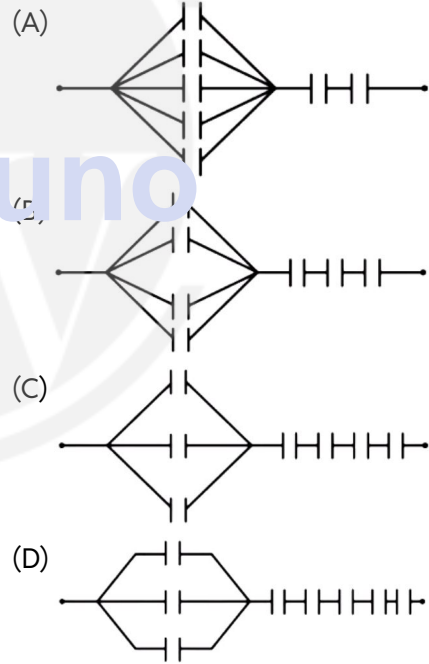

**Q6** In the circuit diagram shown in the adjoining figure, the resultant capacitance between P and Q is



Android App | iOS App | PW Website

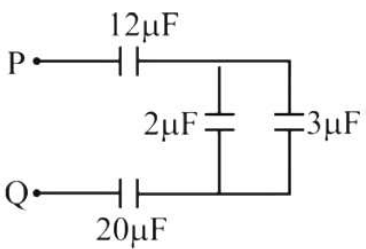

- (A)  $47 \mu\text{F}$                       (B)  $3 \mu\text{F}$
- (C)  $60 \mu\text{F}$                       (D)  $10 \mu\text{F}$

**Q7** Four condensers are joined as shown in the adjoining figure. The capacity of each is  $8 \mu\text{F}$ . The equivalent capacity between the points A and B will be.

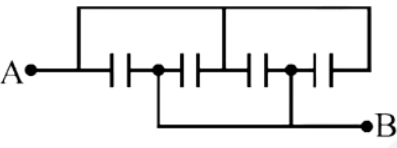

- (A)  $32 \mu\text{F}$                       (B)  $2 \mu\text{F}$
- (C)  $8 \mu\text{F}$                         (D)  $16 \mu\text{F}$

**Q8** The resultant capacitance between A and B in the following figure is equal to

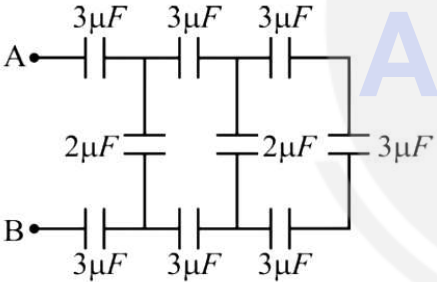

- (A)  $1 \mu\text{F}$                         (B)  $3 \mu\text{F}$
- (C)  $2 \mu\text{F}$                         (D)  $1.5 \mu\text{F}$

**Q9** The total capacity of the system of capacitors shown in the adjoining figure between the points A and B is

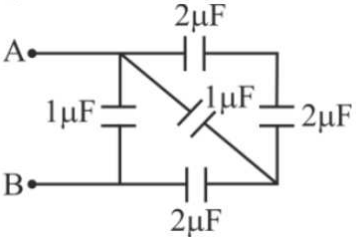

- (A)  $1 \mu\text{F}$                         (B)  $2 \mu\text{F}$
- (C)  $3 \mu\text{F}$                         (D)  $4 \mu\text{F}$

**Q10** Separation between the plates of a parallel plates capacitor is  $d$  and the area of each plate is  $A$ . When a slab of material of dielectric constant  $k$  and thickness  $t$  ( $t < d$ ) is introduced between the plates, its capacitance becomes.

- (A)  $\frac{\epsilon_0 A}{d+t\left(1-\frac{1}{k}\right)}$
- (B)  $\frac{\epsilon_0 A}{d+t\left(1+\frac{1}{k}\right)}$
- (C)  $\frac{\epsilon_0 A}{d-t\left(1-\frac{1}{k}\right)}$
- (D)  $\frac{\epsilon_0 A}{d-t\left(1+\frac{1}{k}\right)}$

**Q11** A dielectric of constant  $K$  is slipped between the plates of parallel plate condenser in half of the space as shown in the figure. If the capacity of air condenser is  $C$ , then new capacitance between A and B will be.

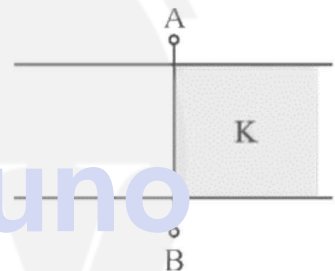

- (A)  $\frac{C}{2}$
- (B)  $\frac{C}{2K}$
- (C)  $\frac{C}{2}(1+K)$
- (D)  $\frac{2(1+K)}{C}$

**Q12** A parallel plates capacitor has a capacity  $C$ . The separation between the plates is doubled and a dielectric medium is introduced between the plates. If the capacity now becomes  $2C$ , the dielectric constant of the medium is.

- (A) 2                                      (B) 1
- (C) 4                                      (D) 8



## Answer Key

**Q1** (i)  $60 \mu C$  (ii)  $300 \mu J$  (iii)  $300 \mu J$  (iv)  
 $150 \mu J$

**Q2** (i)  $C = 2 \mu F$   
(ii)  $V_1 = 6 V$ ,  $V_2 = 12 V$   
(iii)  $Q_1 = Q_2 = CV = 36 \mu C$

**Q3** (i)  $12.5 \mu F$

(ii)  $Q_1=75\mu C$ ,  $Q_2= 50\mu C$ ,  $Q_3= 125\mu C$

(iii)  $V_1=V_2=V_3= 5V$

**Q4** (C)

**Q5** (A)

**Q6** (B)

**Q7** (A)

**Q8** (A)

**Q9** (B)

**Q10** (C)

**Q11** (C)

**Q12** (C)



[Android App](#)

| [iOS App](#)

| [PW Website](#)

ATDB.uno