

CLASS 12 | PHYSICS

DERIVATIONS



ATDB.uno

MADE WITH ❤️

AMAN DHATTARWAL



INDEX

S.NO	TOPIC	PAGE NO.
1.	Electric Field on Axial Line of an Electric Dipole	1
2.	Electric Field on Equatorial Line of Dipole	1
3.	Electric Dipole in Uniform Electric Field	2
4.	Electric Field Due to a Line Charge	2
5.	Electric Field Due to Infinite Charged Plane Sheet	2 – 3
6.	Electric Field Due to Charged Spherical Shell	3
7.	Electric Potential at any point due to an Electric Dipole	4
8.	Potential Energy of an Electric Dipole, when Placed in Uniform Electric Field	4
9.	Parallel Plate Capacitor	4 – 5
10.	Capacitance of Capacitor, when a Dielectric Slab Completely Fills the Space Between Plates	5
11.	Energy Stored in a Charged Capacitor	5
12.	Drift Velocity	7
13.	Relation between Drift Velocity and Electric Current	7
14.	Electric Current and Current Density	8
15.	Cells in Series	8
16.	Cells in Parallel	8 – 9
17.	Wheat Stone Bridge	9
18.	Motion of a charged particle inside a Uniform Magnetic Field	10
19.	Magnetic Field at a point on the Axis of a Loop	11
20.	Force between two infinitely Long Parallel Current Carrying Conductors	11 – 12
21.	Torque on a Current Loop placed in a Magnetic Field	12
22.	Self-Induction (of a Long Solenoid)	13
23.	Mutual Induction (of Two Long Solenoids)	13
24.	Mean or Average Value of A.C.	14
25.	Root Mean Square(rms) or Virtual Value of A.C.	14
26.	A.C. Through LCR-Series Circuit	15 – 16
27.	Power of an A.C. Circuit	16
28.	Mirror Formula (for Concave spherical mirror)	17
29.	Linear Magnification(for Concave spherical mirror)	17
30.	Refraction at Convex Spherical Surface	18
31.	Lens Maker's Formula	18 – 19
32.	Refraction through a Prism	19
33.a	Simple Microscope Magnifying power (Image is formed at D)	20
33.b	Simple Microscope Magnifying power (Image is formed at infinity).	20
34.a	Compound Microscope Magnifying power (Image is formed at D).	21
34.b	Compound Magnifying power (Image is formed at infinity).	21
35.	Astronomical Telescope (Image is formed at infinity).	21

(Physics)

36.	Laws of Reflection on the basis Wave Theory	23
37.	Laws Refraction on the Basis of Wave Theory	23
38.	Conditions for Constructive and Destructive Interference	24
39.	Distance of Closest Approach	25
40.	Bohr's Theory of Hydrogen Atom	25
41.	Nuclear Density	26
42.	Mass Defect	26
43.	Binding Energy	26

ATDB.uno

(Physics)

ELECTRIC FIELD AND CHARGES



1. Electric Field on Axial line of an Electric Dipole

Dipole [3 marks, CBSE 2017, 19, 20, 21]

Consider an electric dipole consisting of charges $-q$ and $+q$, separated by a distance $2a$ and placed in free space.

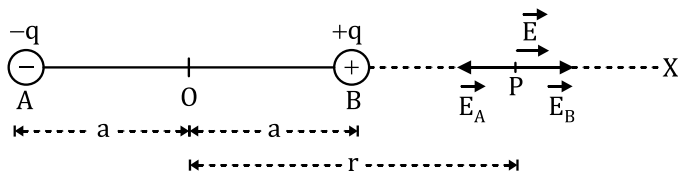

The electric field \vec{E} at point P due to the dipole will be the resultant of the electric fields \vec{E}_A (due to $-q$ at point A) and \vec{E}_B (due to $+q$ at the B) i.e.

$$\vec{E} = \vec{E}_A + \vec{E}_B$$

Also, $|\vec{E}_B| > |\vec{E}_A|$.

$$\vec{E} = ((\vec{E}_B) - (\vec{E}_A)) (\hat{i})$$

$$\text{or } \vec{E} = \frac{1}{4\pi\epsilon_0} \cdot \frac{q}{(r-a)^2} - \frac{1}{4\pi\epsilon_0} \cdot \frac{q}{(r+a)^2}$$

$$= \frac{1}{4\pi\epsilon_0} \cdot q \frac{(r+a)^2 - (r-a)^2}{(r^2 - a^2)^2}$$

$$\vec{E} = \frac{1}{4\pi\epsilon_0} \cdot \frac{q(4ra)}{(r^2 - a^2)^2} (\hat{i})$$

Now, $\vec{P} = q(2a)(\hat{i})$, then,

$$\therefore \vec{E} = \frac{1}{4\pi\epsilon_0} \cdot \frac{2Pr}{(r^2 - a^2)^2} (\hat{i})$$

In vector notation,

$$\vec{E} = \frac{1}{4\pi\epsilon_0} \cdot \frac{2\vec{P}r}{(r^2 - a^2)^2}$$

For dipole is of small length, $a \ll r$;

Therefore,

$$\vec{E} = \frac{1}{4\pi\epsilon_0} \cdot \frac{2\vec{P}r}{r^3}$$

2. Electric Field on Equatorial line of Dipole

[3 marks, CBSE 2016, 20]

Consider an electric dipole consisting of charges $-q$ and $+q$ separated by a distance $2a$.

Then, resultant electric field at point P is given by

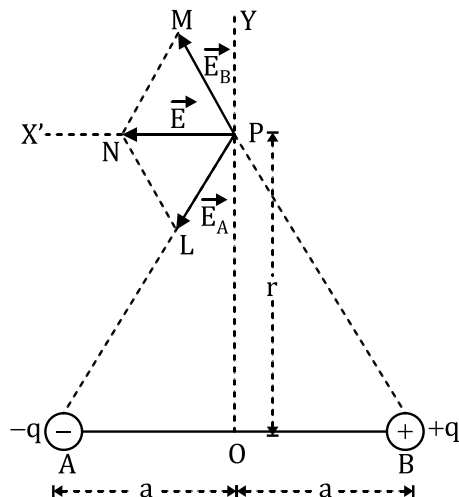

$$\vec{E} = \vec{E}_A + \vec{E}_B$$

Let $\angle MPN = \angle PBN = \theta$.

Also $\angle NPL = \angle PAB = \theta$

$$\text{So, } \vec{E} = \vec{E}_A + \vec{E}_B = (E_A \cos \theta + E_B \cos \theta)(-\hat{i})$$

$$\vec{E} = \vec{E}_A + \vec{E}_B = (2E_A \cos \theta)(-\hat{i})$$

$$= \frac{1}{4\pi\epsilon_0} \cdot \frac{q}{(r^2 + a^2)} \times \frac{2a}{(r^2 + a^2)^{1/2}} (-\hat{i})$$

$$\text{or } \vec{E} = -\frac{1}{4\pi\epsilon_0} \cdot \frac{q(2a)}{(r^2 + a^2)^{3/2}} (-\hat{i})$$

Now $\vec{P} = q(2a)(\hat{i})$, So,

$$\therefore E = \frac{1}{4\pi\epsilon_0} \cdot \frac{P}{(r^2 + a^2)^{3/2}} (-\hat{i})$$

In vector notation,

$$\vec{E} = -\frac{1}{4\pi\epsilon_0} \cdot \frac{\vec{P}}{(r^2 + a^2)^{3/2}}$$

For dipole is of small length, $a \ll r$; then in equation a^2 can be neglected as compared to r^2 .

$$\text{Therefore, } \vec{E} = -\frac{1}{4\pi\epsilon_0} \cdot \frac{\vec{P}}{r^3}$$

3. Electric Dipole in uniform Electric Field

[3 marks, CBSE 19, 20, 21, 22]

Consider an electric dipole consisting of charges $-q$ and $+q$ and of length $2a$ placed in a uniform electric field \vec{E} making an angle θ with the direction of the field.

(Physics)

ELECTRIC FIELD AND CHARGES

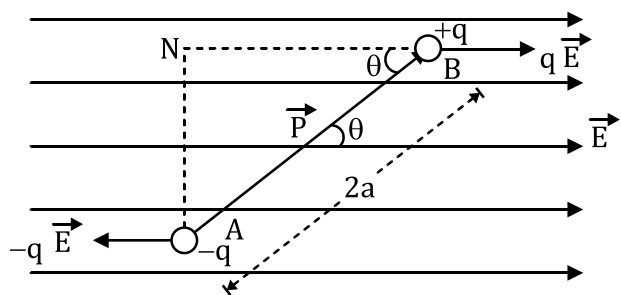

Force on charge $-q$ at $A = -q\vec{E}$

& force on charge $+q$ at $B = q\vec{E}$

So, $\vec{F}_{net} = \vec{F}_{+q} + \vec{F}_{-q} = 0$

Also both forces are equal and opposite and will produce torque on dipole

$\tau = \text{either force} \times \text{perpendicular distance between the two forces}$

$$= qE(AN) = qE(2a \sin \theta) = q(2a)E \sin \theta$$

$$\tau = pE \sin \theta \text{ or } \tau = pE \sin \theta$$

Here, $\vec{P} = q(2a)$, (electric dipole moment)

Also since the dipole rotates in clockwise ($-\hat{k}$) direction so,

$$\text{In vector form } \boxed{\vec{\tau} = \vec{p} \times \vec{E}}$$

4. Electric Field Due to line charge

[3 marks, CBSE 2018, 20]

A thin infinitely long straight line charge having a uniform linear charge density λ placed along YY' . The Gaussian surface for line charge will be cylindrical and from symmetry all the flux will pass from curve surface area.

Let E is the magnitude of electric field at point P , then electric flux through the Gaussian surface is given by

$r = \text{radius of cylinder}$

$l = \text{length of cylinder}$

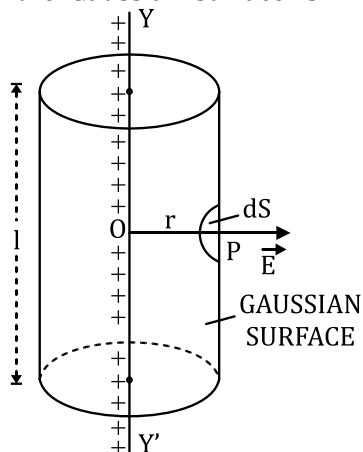

$\Phi = E \times \text{curved surface area of cylinder}$

$$\text{or } \Phi = E \times 2\pi r l \dots (i)$$

According to Gauss' theorem, we have

$$\Phi = \frac{q}{\epsilon_0} \dots (ii)$$

Now, charge enclosed by the Gaussian surface,

$$q = \lambda l$$

$$\therefore \Phi = \frac{\lambda l}{\epsilon_0}$$

From the equations (i) and (ii), we have

$$E \times 2\pi r l = \frac{\lambda l}{\epsilon_0} \text{ or } \boxed{E = \frac{1}{2\pi\epsilon_0} \cdot \frac{\lambda}{r}}$$

5. Electric Field due to infinite Charged

Plane sheet. [2 marks, CBSE 2017, 18]

Consider an infinite thin plane sheet of positive charge having a uniform surface charge density σ on both sides of the sheet.

The Gaussian surface will be a cylinder as shown in figure.

If E is the magnitude of electric field at point P , then electric flux crossing through the gaussian surface,

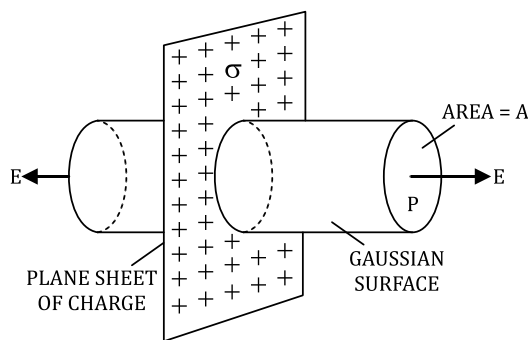

$\Phi = E \times \text{area of the end faces (circular caps) of the cylinder or } \Phi = E \times 2A \dots\dots (i)$

According to Gauss' theorem, we have $\Phi = \frac{q}{\epsilon_0}$

Here, the charge enclosed by the Gaussian surface,

$$q = \sigma A \quad \therefore \Phi = \frac{\sigma A}{\epsilon_0} \dots\dots(ii)$$

From the equations (i) and (ii), we have

$$\boxed{E \times 2A = \frac{\sigma A}{\epsilon_0} \text{ or } E = \frac{\sigma}{2\epsilon_0}}$$

(Physics)

ELECTRIC FIELD AND CHARGES



Thus, we find that the magnitude of the electric field at a point due to an infinite plane sheet of charge is independent of its distance from the sheet of charge.

6. Electric Field due to charged Spherical

Shell [2 or 3 marks, CBSE 2017, 19, 20, 21]

Consider a thin spherical shell of radius R and centre O. Let +q be the charge on the spherical shell.

For all the three surfaces the Gaussian surface will be a sphere.

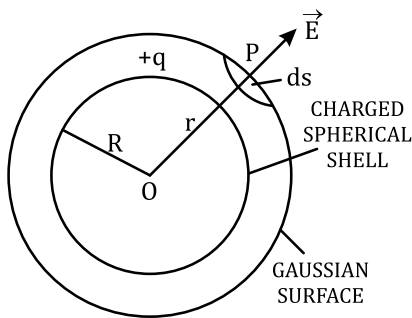

(a) When point P lies outside the shell

Let \vec{E} be the electric field at the point P due to the charged spherical shell.

Consider a small area element $d\vec{S}$ (shown shaded) around the point P.

Then, the electric flux through area element $d\vec{S}$ is given by $d\phi = \vec{E} \cdot d\vec{S} = E ds \cos \theta$

Since $d\vec{S}$ is normal to the surface so $\theta = 0$,
 $d\phi = E ds$

Now total Electric flux is $\oint_S d\phi = \oint_S E ds = E \oint_S ds$

Now, $\oint_S ds =$ surface area of spherical shell of radius $r = 4\pi r^2$

$$\therefore \Phi = E \times 4\pi r^2 \dots (i)$$

the charge enclosed by the gaussian surface is q, so according to the Gauss' theorem,

$$\Phi = \frac{q}{\epsilon_0} \dots (ii)$$

From the equations (i) and (ii), we have

$$E \times 4\pi r^2 = \frac{q}{\epsilon_0} \text{ or } E = \frac{1}{4\pi\epsilon_0} \cdot \frac{q}{r^2} \text{ (for } r > R)$$

(b) When point P lies on the surface of spherical shell

For this case also we will draw a Gaussian surface of just outside the shell, this will enclose charge q of shell completely,

Then according to Gauss' theorem,

$$E \times 4\pi R^2 = \frac{q}{\epsilon_0} \text{ or } E = \frac{1}{4\pi\epsilon_0} \cdot \frac{q}{R^2} \text{ (for } r = R)$$

In a medium of dielectric constant K, the electric field is given by

$$E = \frac{1}{4\pi\epsilon_0 K} \cdot \frac{q}{R^2}$$

(c) When point P lies inside the spherical shell

In such a case, the gaussian surface will be inside the shell and will not enclose any charge and hence according to the Gauss' theorem

$$E \times 4\pi r^2 = \frac{0}{\epsilon_0} \text{ or } \boxed{E = 0} \text{ (for } r < R)$$

(Physics) ELECTROSTATIC POTENTIAL & CAPACITANCE



7. Electric Potential at any point due to an

Dipole [3 marks, CBSE 2017, 18, 20, 21]

AB is a dipole with charge $-q$ and $+q$. P be any point at a distance r from its center O, where electric potential due to the dipole is to be determined.

$\angle POB = \theta$ as shown in fig

Therefore, net potential at point P due to the dipole,

$$V = V_1 + V_2 = -\frac{1}{4\pi\epsilon_0} \cdot \frac{q}{PA} + \frac{1}{4\pi\epsilon_0} \cdot \frac{q}{PB}$$

$$\text{or } V = \frac{1}{4\pi\epsilon_0} \cdot q \left[\frac{1}{PB} - \frac{1}{PA} \right] \quad \dots (i)$$

Draw BN perpendicular to OP and AM perpendicular to PO.

From right angled ΔAMO , we have

$$\cos \theta = \frac{OM}{OA} = \frac{OM}{a} \quad \text{or } OM = a \cos \theta$$

In case the length of the dipole is very small as compared to distance r , then

$$PA \approx PM = PO + OM = r + a \cos \theta$$

$$\text{Similarly, } PB = r - a \cos \theta$$

In the equation (i), substituting for PA and PB, we have

$$\begin{aligned} V &= \frac{1}{4\pi\epsilon_0} \cdot q \left[\frac{1}{r - a \cos \theta} - \frac{1}{r + a \cos \theta} \right] \\ &= \frac{1}{4\pi\epsilon_0} \cdot q \left[\frac{r + a \cos \theta - r + a \cos \theta}{r^2 - a^2 \cos^2 \theta} \right] \\ &= \frac{1}{4\pi\epsilon_0} \cdot q \cdot \frac{2a \cos \theta}{(r^2 - a^2 \cos^2 \theta)} \end{aligned}$$

Since $q(2a) = P$, the electric dipole moment of the dipole, the above equation becomes

$$V = \frac{1}{4\pi\epsilon_0} \cdot \frac{P \cos \theta}{(r^2 - a^2 \cos^2 \theta)} \quad \dots (ii)$$

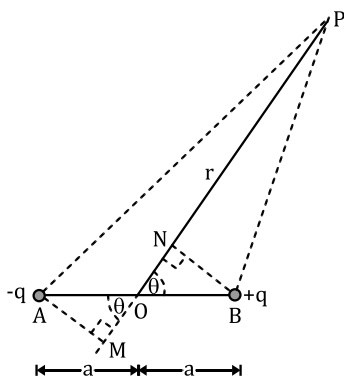

Special cases.

- When point P lies on the **axial line** of the dipole. $\theta = 0^\circ$ and $\cos \theta = \cos 0^\circ = 1$.

Therefore,

$$V_{\text{axial}} = \frac{1}{4\pi\epsilon_0} \cdot \frac{P}{(r^2 - a^2)} \quad \dots (iii)$$

In case $a \ll r$, then

$$V_{\text{axial}} = \frac{1}{4\pi\epsilon_0} \cdot \frac{P}{r^2} \quad \dots (iv)$$

- When point P lies on the **equatorial line** of the dipole. $\theta = 90^\circ$ and $\cos \theta = \cos 90^\circ = 0$

Therefore, the equation (ii) gives

$$V_{\text{equi}} = 0 \quad \dots (v)$$

8. Potential Energy of an Electric Dipole, when Placed in Uniform Electric Field

[3 marks, CBSE 2015, 19, 20, 21]

Let the Dipole be kept along a direction making an angle θ with the direction of an external uniform electric field E . The torque acting on the dipole is given by $\tau = PE \sin \theta$

then work done is rotating the dipole against natural rotation by $d\theta$

$$dW = \tau * d\theta = PE \sin \theta d\theta$$

So, Total work done will be

$$W = \int_{\theta_1}^{\theta_2} PE \sin \theta d\theta = PE * |1 - \cos \theta|_{\theta_1}^{\theta_2}$$

$$\text{or } W = PE(\cos \theta_1 - \cos \theta_2)$$

This work done is stored in the dipole in the form of its potential energy. and so

$$W = \Delta U = PE(\cos \theta_1 - \cos \theta_2)$$

Let $\theta_1 = 90^\circ$ and $\theta_2 = \theta$. Then,

$$U_f - U_i = PE(\cos 90^\circ - \cos \theta)$$

$$\text{or } U_f = -PE \cos \theta$$

In vector notation, $U = -\vec{P} \cdot \vec{E}$

9. Parallel Plate Capacitor

[2/3 marks, CBSE 19, 20, 21, 22]

The capacitor shown has two conducting plates placed parallel to each other kept between Potential

(Physics) ELECTROSTATIC POTENTIAL & CAPACITANCE



Difference 'V'. Separation between plates = d (very small as compared to the area of the plates).

Area of plates = A

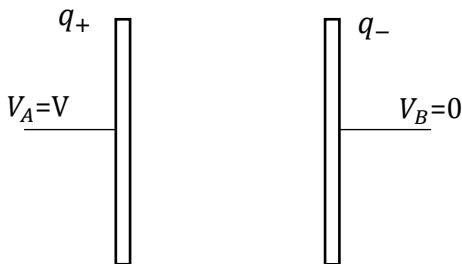

Here the electric field between the two plates is related to the potential gradient as

$$E = \frac{dV}{dr} \text{ (in magnitude)}$$

V is potential difference between the two plates.

$$E = \frac{V}{d} \text{ (For uniform field, } \frac{dV}{dr} = \frac{V}{d} \text{)}$$

$$\text{Or } V = Ed \dots \dots \dots (i)$$

Also Let σ be the surface charge density of the plates, then the electric field between the two plates is given by

$$E = \frac{\sigma}{2\epsilon_0} + \frac{\sigma}{2\epsilon_0} = \frac{\sigma}{\epsilon_0} \text{ (Sum of fields due to both plates)}$$

(ϵ_0 is absolute permittivity of the free space.)

In the equation (i), substituting for E, we have

$$V = \frac{\sigma}{\epsilon_0} d \text{ (} \sigma = \frac{q}{A} \text{)}$$

$$\therefore V = \frac{qd}{\epsilon_0 A}$$

If C is the capacitance of the parallel plate capacitor, then,

$$C = \frac{q}{V} = \frac{q}{\frac{qd}{\epsilon_0 A}} = \frac{\epsilon_0 A}{d} \dots (ii)$$

10. Capacitance of Capacitor, when a Dielectric Slab completely fills the Space between Plates

[3 marks, CBSE 2017, 19, 20, 21]

The capacitor shown has two conducting plates placed parallel to each other kept between Potential Difference 'V'. Separation between plates = d (very small as compared to the area of the plates).

Area of plates = A

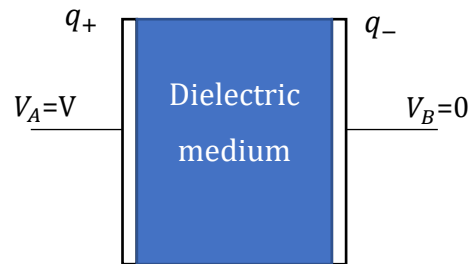

Let the space between the two plates of the capacitor is filled with a dielectric medium of dielectric constant K.

Then, the electric field between the two plates is given by

$$E = \frac{\sigma}{\epsilon_0 K} = \frac{q}{\epsilon_0 KA} \text{ (} \because \sigma = \frac{q}{A} \text{)}$$

If V is potential difference between the two plates of the capacitor separated by a distance d, then $V = Ed$

So substituting the value of E, we have

$$V = \frac{qd}{\epsilon_0 KA}$$

So if C is the capacitance of the parallel plate capacitor, then

$$C = \frac{q}{V} = \frac{q}{\frac{qd}{\epsilon_0 KA}}$$

$$\text{or } C = \frac{\epsilon_0 KA}{d}$$

11. Energy Stored in a Charged Capacitor

[3 marks, CBSE 2016, 19, 20]

A battery is connected across the two plates of the capacitor, the work is done (or energy is supplied) by the battery in charging the capacitor.

The work done in charging a capacitor is stored in the capacitor in the form of electric energy.

Let Capacitance of capacitor = C.

the small amount of work done by the battery to store small charge dq is given by

$$dW = Vdq = \frac{q}{C} dq \text{ (} \because V = \frac{q}{C} \text{)}$$

Therefore, amount of work done in delivering charge q to the capacitor is given by

(Physics) **ELECTROSTATIC POTENTIAL & CAPACITANCE**

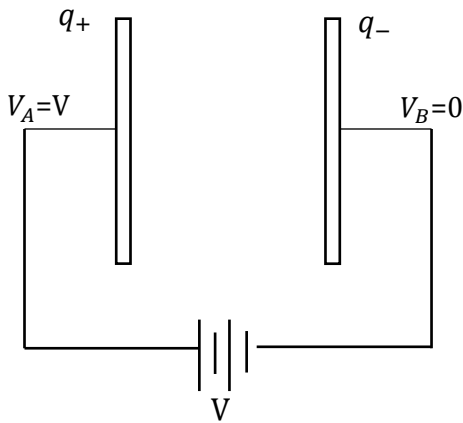

$$W = \int_0^q \frac{q}{C} dq = \frac{1}{C} \int_0^q q dq = \frac{1}{C} \left[\frac{q^2}{2} \right]_0^q = \frac{1}{2} \frac{q^2}{C}$$

This work done is stored inside the capacitor in the form of the electric potential energy. Therefore, energy stored in the capacitor,

$$W = \Delta U = \frac{1}{2} \frac{q^2}{C} \quad \dots (i)$$

since $U_i = 0$ so,

$$U = \frac{1}{2} \frac{q^2}{C} \quad \dots (i)$$

(Substituting for $q = C V$), the equation (i) becomes

$$\text{or } U = \frac{1}{2} C V^2 \quad \dots \dots \dots (ii)$$

In the equation (ii), substituting for $C \left(= \frac{q}{V} \right)$,

we have

$$U = \frac{1}{2} q V \text{ so,}$$

$$\boxed{U = \frac{1}{2} \frac{q^2}{C} = \frac{1}{2} C V^2 = \frac{1}{2} q V}$$

(Physics)

CURRENT ELECTRICITY



12. Drift Velocity

[2 marks, CBSE 2016, 19, 20, 21]

The velocity gained by any electron before the successive collision is called Drift Velocity.

Let $\vec{u}_1, \vec{u}_2, \vec{u}_3, \dots, \vec{u}_n$ are random thermal velocities of n electrons in a conductor, then their average thermal velocity i.e.

$$\frac{\vec{u}_1 + \vec{u}_2 + \vec{u}_3 + \dots + \vec{u}_n}{n} = 0 \quad \dots (i)$$

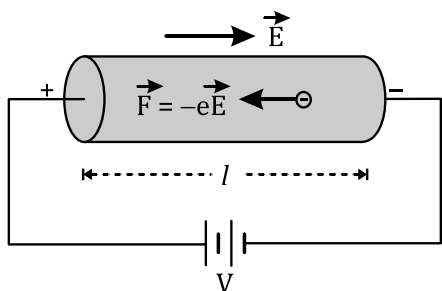

Since charge on an electron is $-e$, each free electron in the conductor experiences a force

$$\vec{F} = -e\vec{E} \quad \dots (ii)$$

If m is mass of the electron, the acceleration given by

$$\vec{a} = \frac{\vec{F}}{m} = -\frac{e\vec{E}}{m} \quad \dots (iii)$$

So final velocity attained after drifting for τ_1 (relaxation time)

$$\vec{v}_1 = \vec{u}_1 + \vec{a}\tau_1$$

Similarly velocities acquired by the other electrons in the conductor will be

$$\vec{v}_2 = \vec{u}_2 + \vec{a}\tau_2, \vec{v}_3 = \vec{u}_3 + \vec{a}\tau_3, \dots, \vec{v}_n = \vec{u}_n + \vec{a}\tau_n$$

Let \vec{v}_d is the average drift velocity of all electrons. So,

$$\vec{v}_d = \frac{\vec{v}_1 + \vec{v}_2 + \vec{v}_3 + \dots + \vec{v}_n}{n} = \frac{(\vec{u}_1 + \vec{a}\tau_1) + (\vec{u}_2 + \vec{a}\tau_2) + (\vec{u}_3 + \vec{a}\tau_3) + \dots + (\vec{u}_n + \vec{a}\tau_n)}{n}$$

Now, $\frac{\tau_1 + \tau_2 + \tau_3 + \dots + \tau_n}{n}$

is called average relaxation time and is denoted by τ .

$$\frac{\vec{u}_1 + \vec{u}_2 + \vec{u}_3 + \dots + \vec{u}_n}{n} = 0$$

Therefore the, above equation becomes

$$\vec{v}_d = 0 + \vec{a}\tau = \vec{a}\tau$$

(Using the equation (iii), we have)

$$\vec{v}_d = -\frac{e\vec{E}}{m}\tau$$

13. Relation between Drift Velocity and Electric Current

[1/2 marks, CBSE 2018, 19, 20, 21]

Let, length of conductor = L & area of cross-section = A . then, volume = AL

Let n be the number of free electrons per unit volume, $n = N/V$

So, total charge on all the free electrons

$$= q = Ne = nALe \quad \dots (i)$$

Time taken by the free electrons to cross the length of the conductor

$$t = \frac{l}{v_d} \quad \dots (ii)$$

Also we know, $I = \frac{q}{t}$

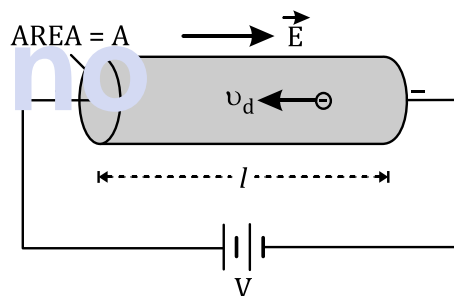

Using the equations (i) and (ii), we have

$$I = \frac{nAle}{l/v_d} \text{ or } I = nAv_d e \quad \dots (iii)$$

Also $v_d = \frac{eE}{m}\tau$

So, $I = \frac{nAe^2\tau}{m} E \quad \dots (v)$

14. Electric Current and Current Density [3 marks, CBSE 2017, 18, 21]

Current density (\vec{j}) is a vector

If the current flowing through the conductor is uniform over its cross section, then current may be defined as

$$I = \vec{j} \cdot \vec{A}, \quad \dots (i)$$

Where \vec{A} = area vector representing the area of cross-section.

(Physics)

CURRENT ELECTRICITY



For non-uniform cross-section, the current through a small area \vec{dA} is given by

$$dI = \vec{j} \cdot \vec{dA}$$

Hence, the current through the whole cross-section of the conductor is given by

$$I = \int \vec{j} \cdot \vec{dA} \quad \dots (ii)$$

If current density \vec{j} is normal to the cross-sectional area i.e. if \vec{j} is parallel to \vec{A} , then

$$I = jA$$

Putting $I = nAv_d e$

$$\boxed{\vec{j} = n\vec{v}_d e} \quad \dots (iii)$$

15. Cells in Series

[3 marks, CBSE 2017, 19]

When cells are of different EMF's. & internal resistances.

Let E_1 and E_2 are EMF's and internal resistances r_1 and r_2 of cells. In series $I = \text{Constant}$

Then, the terminal potential difference across the first cell,

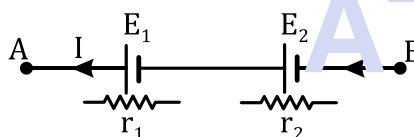

$$V_1 = E_1 - Ir_1$$

Similarly, the terminal potential difference across the second cell,

$$V_2 = E_2 - Ir_2$$

If V is the potential difference between the points A and B, then

$$V = V_1 + V_2 = (E_1 - Ir_1) + (E_2 - Ir_2)$$

$$\text{or } V = (E_1 + E_2) - I(r_1 + r_2) \quad \dots (i)$$

Let E be the battery with internal resistance r that can replace both E_1 and E_2 which withdraws same current I between A & B then,

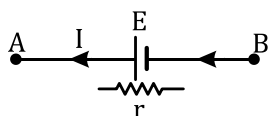

$$V = E - Ir \quad \dots (ii)$$

Comparing the equations (i) and (ii), we have

$$\mathbf{E = E_1 + E_2} \quad \dots (iii)$$

$$\text{and } \mathbf{r = r_1 + r_2} \quad \dots (iv)$$

If the series combination of the two cells provides the current I through an external resistance R , then

$$I = \frac{E}{R + r}$$

Substituting for E and r , we have

$$I = \frac{E_1 + E_2}{R + (r_1 + r_2)}$$

16. Cells in Parallel

[2 marks, CBSE 2018, 19, 21]

When cells are of different e.m.f and internal resistances.

Let E_1 and E_2 are EMF's and internal resistances r_1 and r_2 of cells. In parallel combination terminal potential V is constant across two cells (between A & B) that provides a current I .

If I_1 and I_2 are the currents due to the two cells, then

$$I = I_1 + I_2 \quad \dots (i)$$

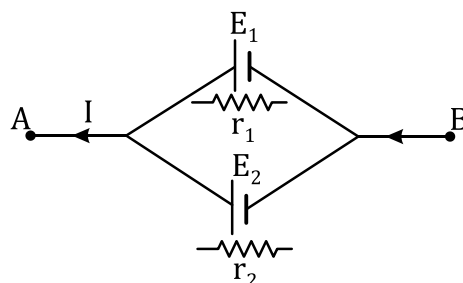

For 1st cell

$$V = E_1 - I_1 r_1$$

$$\text{or } I_1 = \frac{E_1 - V}{r_1}$$

For 2nd cell

$$I_2 = \frac{E_2 - V}{r_2}$$

Substituting for I_1 and I_2 in eq (i), we have

$$I = \frac{E_1 - V}{r_1} + \frac{E_2 - V}{r_2}$$

$$\text{or } I = \left(\frac{E_1}{r_1} + \frac{E_2}{r_2} \right) - V \left(\frac{1}{r_1} + \frac{1}{r_2} \right)$$

(Physics)

CURRENT ELECTRICITY



$$\text{or } V = \left(\frac{E_1 r_2 + E_2 r_1}{r_1 + r_2} \right) - I \left(\frac{r_1 r_2}{r_1 + r_2} \right) \dots \text{(ii)}$$

Let E is effective e.m.f. and r, the effective internal resistance of the parallel combination of the two cells [Fig.],

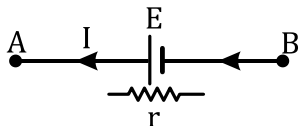

then it follows that

$$V = E - Ir \dots \text{(iii)}$$

Comparing the equations (ii) and (iii), we have

$$E = \frac{E_1 r_2 + E_2 r_1}{r_1 + r_2} \dots \text{(iv)}$$

and
$$r = \frac{r_1 r_2}{r_1 + r_2} \dots \text{(v)}$$

17. Wheat Stone Bridge

[3 marks, CBSE 2018, 19, 21, 22]

P, Q, R and X are 4 resistances. A galvanometer G and a tapping key K_1 (called galvanometer key) are connected between points B and D.

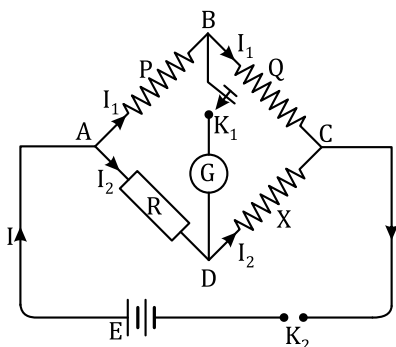

Also Battery E is connected between A & C

Let I = current in the main circuit.

I_1 = Current through resistance P & Q

$I - I_1 = I_2$ (say) = Current through resistance R & X.

For balanced wheat stone bridge, points B and D are at the same potential & $I_g = 0$

Let V_A, V_B, V_C and V_D be electric potentials of points A, B, C and D respectively.

Now, potential difference across P, Q, R, X are

$$V_A - V_B = I_1 P \dots \text{(i)}$$

$$V_D - V_C = I_1 Q \dots \text{(ii)}$$

$$V_A - V_D = I_2 R \dots \text{(iii)}$$

$$V_D - V_C = I_2 X \dots \text{(iv)}$$

When the bridge is in balanced state, $V_B = V_D$.

So, putting values

$$V_A - V_B = I_2 R \dots \text{(v)}$$

$$V_B - V_C = I_2 X \dots \text{(vi)}$$

From the equations (i) and (v), we have

$$I_1 P = I_2 R \dots \text{(vii)}$$

From the equations (ii) and (vi), we have

$$I_1 Q = I_2 X$$

Dividing the equation (vii) by (viii), we have

$$\frac{P}{Q} = \frac{R}{X}$$

(Physics)

MOVING CHARGE AND MAGNETISM



18. Motion of a Charged particle inside a Uniform Magnetic Field

Force experienced by charged particle

$$\vec{F} = q(\vec{v} \times \vec{B}) \quad \dots (i)$$

\vec{F} is always perpendicular to \vec{v} , so force will act as centripetal force.

(a) When \vec{v} is perpendicular to \vec{B} .

The force \vec{F} on the charged particle acts as the centripetal force and makes it to move along a circular path.

m = mass of the charged particle &
 r = radius of the circular path, then

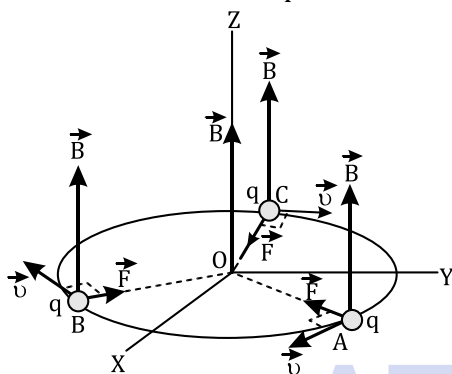

$$|q(\vec{v} \times \vec{B})| = \frac{mv^2}{r}$$

Since \vec{v} & \vec{B} are at right angles to each other, so

$$|q(\vec{v} \times \vec{B})| = Bqv$$

$$\text{or } Bqv = \frac{mv^2}{r}$$

$$\boxed{r = \frac{mv}{Bq}} \quad \dots (ii)$$

The period of circular motion of the charged particle is given by

$$T = \frac{2\pi r}{v} = \frac{2\pi}{v} \times \frac{mv}{Bq} \text{ or } \boxed{T = \frac{2\pi m}{Bq}} \quad \dots (iii)$$

Also angular frequency of the charged particle

$$\omega = \frac{2\pi}{T} = \frac{2\pi}{\frac{2\pi m}{Bq}} \text{ or } \boxed{\omega = \frac{Bq}{m}} \quad \dots (iv)$$

(b) When \vec{v} and \vec{B} are inclined to each other.

The charged particle is moving with velocity \vec{v} inside the uniform magnetic field B making an angle θ with the direction of the magnetic field.

The velocity \vec{v} of the charged particle can be resolved into the following two components:

- (i) $v_B = v \cos \theta$ (Component of velocity along B) (No contribution in force)

- (ii) $v_n = v \sin \theta$

(Component of velocity perpendicular to B)

$$\text{So, } r = \frac{mv_n}{Bq} = \frac{mv \sin \theta}{Bq} \quad \dots (v)$$

The period of the circular path is given by

$$T = \frac{2\pi r}{v_n} = \frac{2\pi}{v \sin \theta} \times \frac{mv \sin \theta}{Bq} \text{ or } T = \frac{2\pi m}{Bq}$$

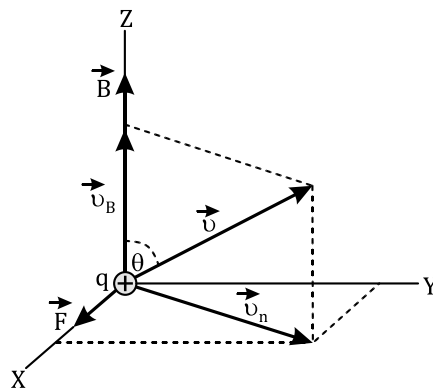

The charged particle moves along circular path in XY-plane due to the velocity component v_n , it also advances linearly helical path.

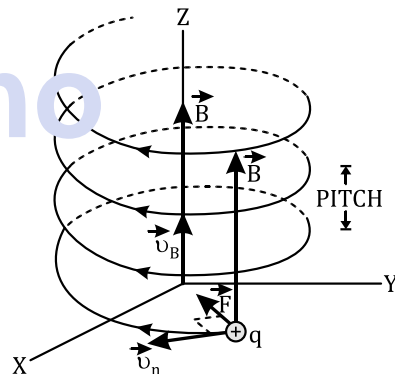

Now, Pitch = the distance travelled by the charged particle, along the direction of magnetic field in a time it completes one revolution.

$$\text{pitch of the helical path} = v_B \times T$$

$$= v \cos \theta \times \frac{2\pi m}{Bq}$$

$$\text{or pitch of the helical path} = \boxed{\frac{2\pi m v \cos \theta}{Bq}} \quad \dots (vi)$$

19. Magnetic Field at a point on the Axis of a Loop

[3 marks, CBSE 2017, 18, 19, 20, 21]

Consider a circular loop of radius a , centre O and carrying a current I as shown.

(Physics)

MOVING CHARGE AND MAGNETISM

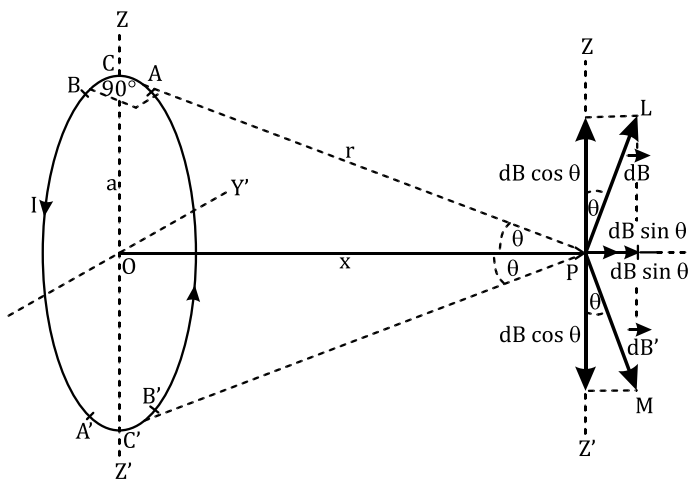

Let P be the point on the axis of the loop at a distance $OP = x$ from its centre O, Let $AB = dl$ be small current element of the loop.

Also $\angle BCP$ (or $\angle ACP$) is equal to 90° .

According to Biot Savart's law, the magnetic field due to the current element AB at point P is given by

$$d\vec{B} = \frac{\mu_0}{4\pi} \cdot \frac{I d\vec{l} \times \vec{r}}{r^3}$$

The angle between $d\vec{l}$ and \vec{r} is 90° . The magnitude of $d\vec{B}$ is given by

$$dB = \frac{\mu_0}{4\pi} \cdot \frac{Idl}{r^2} \quad \dots (i)$$

Another element $A'B' = dl$ located just opposite to the element AB. $d\vec{B}' =$ Mag Field due to the current element $A'B'$.

If $\angle OPC = \angle OPC' = \theta$, then $\angle ZPL = \angle Z'PM = \theta$.

On resolving the $\cos \theta$ components gets cancelled out and only $\sin \theta$ gets added so,

$$B = \oint dB \sin \theta = \oint \frac{\mu_0}{4\pi} \cdot \frac{Idl}{r^2} \sin \theta$$

$$= \frac{\mu_0}{4\pi} \cdot \frac{I}{r^2} \sin \theta \oint dl$$

$$\oint dl = 2\pi a$$

$$\therefore B = \frac{\mu_0}{4\pi} \cdot \frac{I}{r^2} \sin \theta (2\pi a) = \frac{\mu_0}{4\pi} \cdot \frac{2\pi Ia}{r^2} \sin \theta$$

$$\therefore B = \frac{\mu_0}{4\pi} \cdot \frac{2\pi Ia}{r^2} \times \frac{a}{r} = \frac{\mu_0}{4\pi} \cdot \frac{2\pi Ia^2}{r^3}$$

$$\therefore B = \frac{\mu_0}{4\pi} \cdot \frac{2\pi Ia^2}{(a^2 + x^2)^{3/2}}$$

Also for 'N' turns

$$B = \frac{\mu_0}{4\pi} \cdot \frac{2\pi NIa^2}{(a^2 + x^2)^{3/2}}$$

Special cases.

1. Magnetic field at the center of the loop. ($x=0$)

$$B = \frac{\mu_0}{4\pi} \cdot \frac{2\pi NI}{a}$$

20. Force between two infinitely Long Parallel Current Carrying Conductors

[3 marks, CBSE 2017, 19, 20, 21, 22]

Consider two infinitely long conductors X_1Y_1 and X_2Y_2 placed parallel to each other at a distance r apart with I_1 and I_2 current flowing through them in the same direction.

Let B_1 & B_2 be magnetic fields of wire 1 & 2 so,

$$B_1 = \frac{\mu_0}{4\pi} \cdot \frac{2I_1}{r}, B_2 = \frac{\mu_0}{4\pi} \cdot \frac{2I_2}{r}$$

The wire 1 will experience Magnetic force due to field of wire 2 & Vice versa

**L is the length of wires on which F is calculated

$$\therefore \vec{F}_{1,2} = I_1(\vec{L} \times \vec{B}_2) = \frac{\mu_0}{4\pi} \cdot \frac{2I_2}{r} \times I_1 \times L (-\hat{i})$$

(Force on wire 1 due to magnetic field of wire 2)

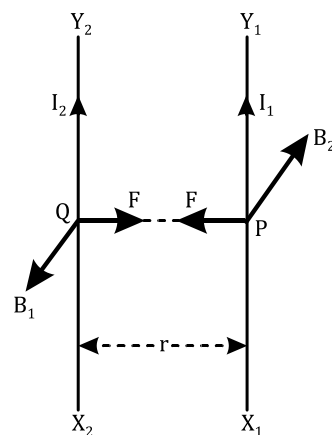

$$\text{or } \frac{\vec{F}_{1,2}}{L} = \frac{\mu_0}{4\pi} \cdot \frac{2I_1I_2}{r} (-\hat{i}) \quad \dots (i)$$

$$\text{Also } \vec{F}_{2,1} = I_2(\vec{L} \times \vec{B}_1) = \frac{\mu_0}{4\pi} \cdot \frac{2I_1}{r} \times I_2 \times L (\hat{i})$$

(Force on wire 2 due to magnetic field of wire 1)

$$\text{or } \frac{\vec{F}_{2,1}}{L} = \frac{\mu_0}{4\pi} \cdot \frac{2I_1I_2}{r} (\hat{i})$$

This shows that Force per unit length on both wires is equal and opposite.

(Physics)

MOVING CHARGE AND MAGNETISM



21. Torque on a Current Loop placed in a Magnetic Field [3 marks, CBSE 2017, 18, 19]

A rectangular coil ABCD with side a & b , carrying a current I is suspended in a uniform magnetic field \vec{B} acting in the plane of the paper from left to right.

$\vec{F}_1, \vec{F}_2, \vec{F}_3$ and \vec{F}_4 be the forces acting on arms DA, BC, AB and CD of the coil respectively in the magnetic field.

Here AB = a , BC = b, CD = a , DA = b

Also θ is the angle between Normal to plane and magnetic field.

It follows that the force on arm DA,

$$\vec{F}_1 = I(\vec{DA}) \times \vec{B},$$

$$\vec{F}_1 = I(\vec{DA}) \times |\vec{B}| \sin(90^\circ + \theta) \hat{j} = BIb \cos \theta (\hat{j})$$

Similarly,

$$\vec{F}_2 = I(\vec{BC}) \times \vec{B},$$

$$\begin{aligned} \vec{F}_2 &= I(\vec{BC}) \times |\vec{B}| \sin(90^\circ - \theta) (-\hat{i}) \\ &= IbB \cos \theta (-\hat{i}) \end{aligned}$$

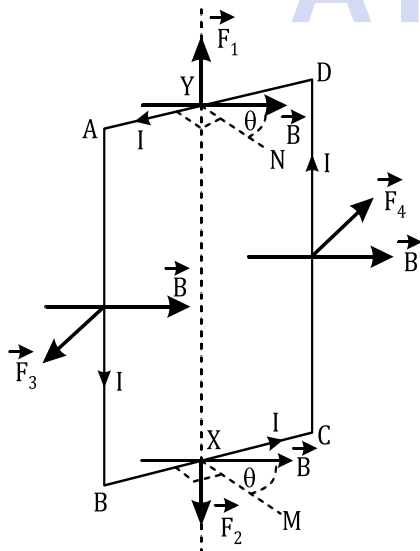

$$\vec{F}_3 = I(\vec{AB}) \times |\vec{B}| \sin 90^\circ (-\hat{i}) = (Ia)B(1) = BIa(-\hat{i})$$

$$\vec{F}_4 = I(\vec{CD}) \times |\vec{B}| \sin 90^\circ (\hat{i}) = (Ia)B(1) = BIa(\hat{i})$$

$$\text{So, } \vec{F}_{\text{loop}} = \vec{F}_1 + \vec{F}_2 + \vec{F}_3 + \vec{F}_4 = 0.$$

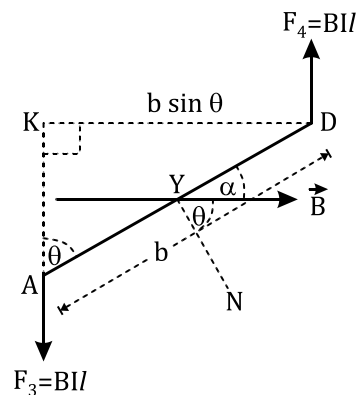

As the two forces \vec{F}_3 & \vec{F}_4 have different lines of action, they constitute a torque, whose magnitude is given by

$$\tau = \text{either force} \times KD,$$

$$\tau = BaI \times b \sin \theta$$

$$= b \cdot A \sin \theta \quad (\text{Area} = A = a \times b)$$

Also, $I\vec{A} = \vec{M}$ the magnetic dipole moment of the current loop. Therefore,

$$\tau = M B \sin \theta$$

$$\vec{\tau} = \vec{M} \times \vec{B}$$

Note : If the coil has N turns, then

$$\tau = N B I A \sin \theta$$

(Physics)

ELECTROMAGNETIC INDUCTION



22. Self-Induction

The phenomenon, according to which an opposing induced e.m.f. is produced in a coil as a result of change in current or magnetic flux linked with the coil itself, is called self-induction.

it is also called back e.m.f.

Self-Inductance of a Long Solenoid

[3 marks, CBSE 2017, 19, 21]

Let L = Length of coil,

A = Area of cross section,

n = number of turns per unit length = N/L

I = current passing through solenoid (coil)

Then, magnetic field inside the solenoid is given by

$$B = \mu_0 n I$$

The magnetic (self) flux passing through each turn of the coil = B × area of each turn = $\mu_0 n I \times A$

Total magnetic flux linked with the solenoid,

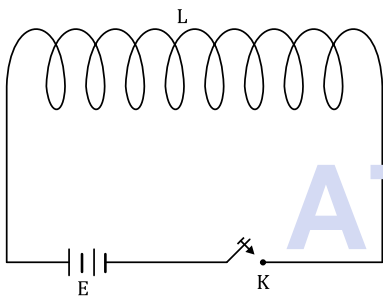

ϕ = Magnetic flux linked with one turn × total number of turns

Now, total number of turns in the solenoid = nL

$$\therefore \phi = \mu_0 n I A \times n L \text{ or } \phi = \mu_0 n^2 L A I \quad \dots (i)$$

If L is the self-inductance of the solenoid, then

$$\phi = L I \quad \dots (ii)$$

On comparing

$$L = \frac{\mu_0 N^2 A}{L} \quad \dots (iii)$$

23. Mutual Induction

The phenomenon according to which an opposing e.m.f. is produced in a coil as a result of change in current or magnetic flux linked with a neighboring coil is called mutual induction.

Mutual Inductance of Two Long Solenoids

[3 marks, CBSE 2017, 19, 20, 21]

. Let I_1 & I_2 be the current flowing in given coils(solenoids).

L = Lengths of both solenoids S_1 and S_2 , such that the solenoid S_2 surrounds the solenoid S_1 completely

n_1, n_2 = number of turns per unit length of the solenoids S_1 and S_2 respectively.

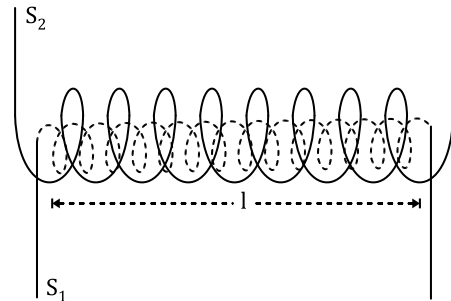

$$\phi_{21} \propto I_1$$

or $\phi_{21} = M_{21} I_1, \dots (i)$ (M_{21} is the coefficient of mutual induction of S_2 due to S_1)

Also, $B_1 = \mu_0 n_1 I_1$ (mag field produced inside the solenoid S_1 due to I_1)

So, total magnetic flux linked with the solenoid S_2 ,

$$\begin{aligned} \phi_{21} &= B_1 A \times n_2 L = \mu_0 n_1 I_1 \times A \times n_2 L \\ &= \mu_0 n_1 n_2 A I_1 L \quad (ii) \end{aligned}$$

On comparing (i) & (ii) $M_{21} = \mu_0 n_1 n_2 A L$

Similarly

$$\phi_{12} \propto I_2 \text{ or } \phi_{12} = M_{12} I_2, \quad \dots (iii)$$

($M_{1,2}$ is the coefficient of mutual induction of S_1 due to S_2)

Also, $B_2 = \mu_0 n_2 I_2$ (mag field produced inside the solenoid S_1 due to I_2)

Therefore, total magnetic flux linked with the solenoid S_1 ,

$$\begin{aligned} \phi_{12} &= B_2 A \times n_1 L = \mu_0 n_2 I_2 \times A \times n_1 L \\ \text{or } \phi_{12} &= \mu_0 n_1 n_2 A I_2 L \quad \dots (iv) \end{aligned}$$

on comparing (iii) & (iv) $M_{12} = \mu_0 n_1 n_2 A L$

Therefore,

$$M_{21} = M_{12} = M \text{ (say)}$$

Hence, coefficient of mutual induction between the two long solenoids,

$$M = \mu_0 n_1 n_2 A L$$

(Physics)

ALTERNATING CURRENT



24. Mean or Average Value of A.C.

[3 marks, CBSE 2017, 18, 21, 22]

Let $I = I_0 \sin \omega t$ is current in any circuit

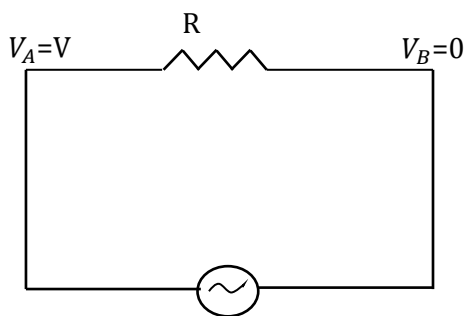

Let the small amount of charge that will pass through the circuit in time dt is given by

$$dq = Idt \text{ or } dq = I_0 \sin \omega t dt$$

The amount of charge that will pass through the circuit in time $T/2$ (half time period of a.c.) is the total integral value of above equation from $t = 0$ to $t = T/2$ i.e.

$$q = \int_0^{T/2} I_0 \sin \omega t dt = I_0 \int_0^{T/2} \sin \omega t dt$$

$$= I_0 \left[-\frac{\cos \omega t}{\omega} \right]_0^{T/2} = -\frac{I_0}{\omega} [\cos \omega t]_0^{T/2}$$

$$= -\frac{I_0}{2\pi} \left[\cos \frac{2\pi}{T} \cdot \frac{T}{2} - \cos \frac{2\pi}{T} \cdot 0 \right]$$

$$= -\frac{I_0 T}{2\pi} [\cos \pi - \cos 0] = -\frac{I_0 T}{2\pi} (-1 - 1).$$

or $q = \frac{I_0 T}{\pi}$

If I_m is mean value of a.c., then by definition

$$q = I_m \cdot \frac{T}{2}$$

From the equations (i) and (ii), we have

$$I_m \cdot \frac{T}{2} = \frac{I_0 T}{\pi} \text{ or } \boxed{I_m = \frac{2I_0}{\pi} = 0.636I_0}$$

25. Root Mean Square (rms) or Virtual Value of A.C. [3 marks, CBSE 2017, 18, 19, 21]

Let $I = I_0 \sin \omega t$ is current in any circuit

The current through the resistance remains constant for an infinitesimally small time dt so the

small amount of heat produced in the resistance R in time dt is given by

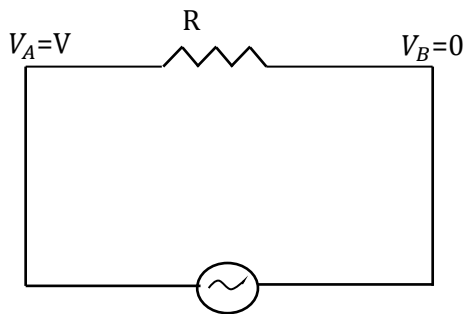

$$dH = I^2 R dt = (I_0 \sin \omega t)^2 R dt = I_0^2 R \sin^2 \omega t dt$$

The amount of heat produced in the resistance in time $T/2$ (half time period) can be obtained by integrating the above equation between the limits $t = 0$ to $t = T/2$ i.e.

$$H = \int_0^{T/2} I_0^2 R \sin^2 \omega t dt = I_0^2 R \int_0^{T/2} \sin^2 \omega t dt$$

$$= I_0^2 R \int_0^{T/2} \frac{1 - \cos 2\omega t}{2} dt$$

or $H = \frac{I_0^2 R}{2} \left(\int_0^{T/2} dt - \int_0^{T/2} \cos 2\omega t dt \right) \dots (i)$

In the equation (i), substituting the values of the two integrals obtained above, we have

$$H = \frac{I_0^2 R}{2} \left(\frac{T}{2} - 0 \right) = \frac{I_0^2 R}{2} \cdot \frac{T}{2} \dots (ii)$$

If I_v is virtual or r.m.s. value of a.c., then by definition,

$$H = I_v^2 R \cdot \frac{T}{2} \dots (iii)$$

From the equations (ii) and (iii), we have

$$I_v^2 R \cdot \frac{T}{2} = \frac{I_0^2 R}{2} \cdot \frac{T}{2} \text{ or } I_v^2 = \frac{I_0^2}{2}$$

or $\boxed{I_v = \frac{I_0}{\sqrt{2}} = 0.707I_0}$

(Physics)

ALTERNATING CURRENT



26. A.C. Through LCR-Series Circuit

[3 marks, CBSE 2017, 18, 19, 20, 21]

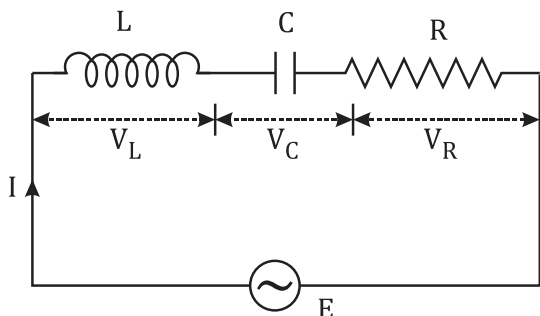

Let E and I be the instantaneous values of e.m.f. and current in the LCR circuit; and V_L, V_C and V_R be the instantaneous values of the voltages across inductor L , capacitor C and resistor R respectively.

Then, $V_L = IX_L; V_C = IX_C$ and $V_R = IR$

Here, $X_L = \omega L$ and $X_C = 1/\omega C$ are reactances due to inductor and capacitor respectively. Where ω is the angular frequency of given supply.

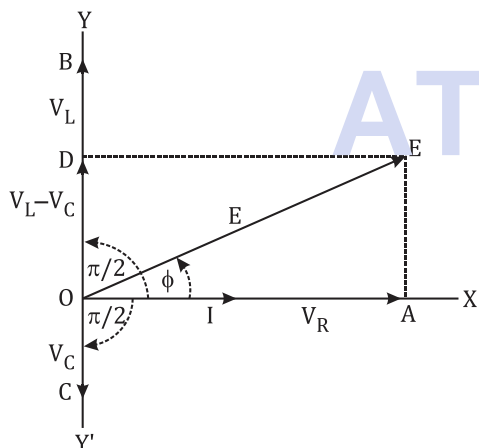

$$OE = \sqrt{OA^2 + AE^2} = \sqrt{OA^2 + OD^2} \text{ (Pythagoras)}$$

$$\text{or } E = \sqrt{V_R^2 + (V_L - V_C)^2}$$

Substituting the values of V_R, V_L and V_C , we have

$$E = \sqrt{(IR)^2 + (IX_L - IX_C)^2}$$

$$= I\sqrt{R^2 + (X_L - X_C)^2}$$

$$\text{or } I = \frac{E}{\sqrt{R^2 + (X_L - X_C)^2}} \quad \dots (i)$$

$$\text{Let, } I = \frac{E}{Z} \quad \dots (ii)$$

From the equations (i) and (ii), we have

$$Z = \sqrt{R^2 + (X_L - X_C)^2}$$

$$= \sqrt{R^2 + (\omega L - 1/\omega C)^2} \quad \dots (iii)$$

The equation (iii) gives **impedance** of LCR-circuit.

Also phase angle ϕ From right angled $\triangle OAE$, we have

$$\tan \phi = \frac{AE}{OA} = \frac{V_L - V_C}{V_R} = \frac{IX_L - IX_C}{IR}$$

$$\text{or } \boxed{\tan \phi = \frac{X_L - X_C}{R} = \frac{\omega L - \frac{1}{\omega C}}{R}} \quad \dots (iv)$$

27. Power of an A.C. Circuit

The small amount of electrical energy consumed in circuit is given by the work done by battery. So,

$$dW = EIdt = (E_0 \sin \omega t)I_0 \sin(\omega t + \phi) dt$$

$$= E_0 I_0 \sin \omega t (\sin \omega t \cos \phi + \cos \omega t \sin \phi) dt$$

$$= E_0 I_0 (\sin^2 \omega t \cos \phi + \sin \omega t \cos \omega t \sin \phi) dt \quad \dots (i)$$

Now, $\cos 2\omega t = 1 - 2\sin^2 \omega t$ Or

$$\sin^2 \omega t = \frac{1 - \cos 2\omega t}{2}$$

Also, $\sin 2\omega t = 2 \sin \omega t \cos \omega t$ or

$$\sin \omega t \cos \omega t = \frac{\sin 2\omega t}{2}$$

In the equation (i), substituting for $\sin^2 \omega t$ and $\sin \omega t \cos \omega t$ we have

$$dW = E_0 I_0 \left(\frac{1 - \cos 2\omega t}{2} \cos \phi + \frac{\sin 2\omega t}{2} \sin \phi \right) dt$$

$$= \frac{E_0 I_0}{2} (\cos \phi - \cos \phi \cos 2\omega t + \sin \phi \sin 2\omega t) dt$$

The electrical energy consumed in the circuit in time T (period of a.c.) can be obtained by integrating the above equation between $t = 0$ to $t = T$ i.e.

$$W = \int_0^T \frac{E_0 I_0}{2} (\cos \phi - \cos \phi \cos 2\omega t + \sin \phi \sin 2\omega t) dt$$

$$W = \frac{E_0 I_0}{2} [\cos \phi(T) - \cos \phi(0) + \sin \phi(0)]$$

$$\text{or } W = \frac{E_0 I_0 T}{2} \cos \phi$$

The average power of the a.c. circuit is given by

$$P_{avg} = \frac{W}{T} = \frac{E_0 I_0 T}{2} \cos \phi \times \frac{1}{T} = \frac{E_0 I_0}{2} \cos \phi$$

$$\frac{E_0}{\sqrt{2}} \cdot \frac{I_0}{\sqrt{2}} \cos \phi$$

$$\boxed{P_{avg} = E_v I_v \cos \phi} \quad \dots (ii)$$

(Physics)

ALTERNATING CURRENT



Here $\cos \phi = \frac{R}{Z}$ is called the power factor of circuit.

& E_v & I_v are RMS value of voltage and current

Special cases :

(i) circuit having R only. For such a circuit, $\phi = 0$.

$$P_{av} = E_v I_v \cos 0 = E_v I_v (1) = E_v I_v$$

(ii) circuit having L only. For such a circuit,

$$\phi = \pi/2 .$$

$$P_{av} = E_v I_v \cos \pi/2 = E_v I_v (0) = 0$$

(iii) circuit containing C only. For such a circuit,

$$\phi = -\pi/2$$

$$P_{av} = E_v I_v \cos(-\pi/2) = E_v I_v (0) = 0$$

ATDB.uno

(Physics)

RAY OPTICS & OPTICAL INSTRUMENTS



28. Mirror Formula

[3 marks, CBSE 2017, 18, 20]

For Concave spherical mirror

Let the points P, F and C be the pole, focus and centre of curvature of a concave spherical mirror.

AB = Object

Now, triangles A'B'F and ENF are similar.

$$\therefore \frac{A'B'}{NE} = \frac{A'F}{NF}$$

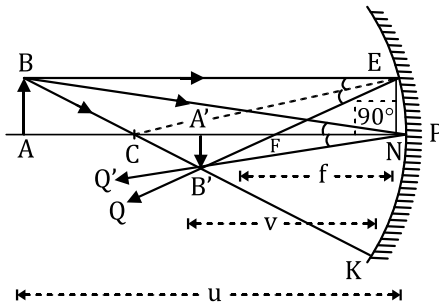

As aperture of the concave mirror is small, the points N and P lie very close to each other and consequently $NF \approx PF$. Also, $NE = AB$.

$$\therefore \frac{A'B'}{AB} = \frac{A'F}{PF}$$

Since all the distances are to be measured from the pole of the concave mirror, we have

$$A'F = PA' - PF$$

$$\therefore \frac{A'B'}{AB} = \frac{PA' - PF}{PF} \dots (i)$$

Also, triangles ABP and A'B'P are similar.

$$\therefore \frac{A'B'}{AB} = \frac{PA'}{PA} \dots (ii)$$

From the equations (i) and (ii), we have

$$\frac{PA' - PF}{PF} = \frac{PA'}{PA} \dots (iii)$$

Applying the new cartesian sign conventions, we have

$$PA = -u \text{ (Object distance)}$$

$$PA' = -v \text{ (Image dist.) and } PF = -f \text{ (focal length)}$$

In the equation (iii), substituting for PA, PA' and PF, we have

$$\frac{-v - (-f)}{-f} = \frac{-v}{-u} \text{ or } \frac{v - f}{f} = \frac{v}{u} \text{ or } \frac{v}{f} - 1 = \frac{v}{u}$$

$$\text{or } \frac{1}{f} - \frac{1}{v} = \frac{1}{u} \text{ or } \frac{1}{u} + \frac{1}{v} = \frac{1}{f}$$

The above relation between u, v and f is called mirror formula.

29. Linear Magnification

[2marks, CBSE 2017, 18, 20, 22]

The ratio of the size of the image formed by a spherical mirror to the size of the object is called the linear magnification.

$$m = \frac{I}{O} \dots (i)$$

Magnification produced by a concave mirror

Fig. shows the formation of the image A'B' of an object AB by a concave spherical mirror. Since the triangles ABP and A'B'P are similar, we have

$$\frac{A'B'}{AB} = \frac{PA'}{PA}$$

Applying the new

Cartesian sign

conventions, we have

$$A'B' = -I$$

$$AB = +O$$

$$PA = -u$$

$$PA' = -v$$

(\because distance of image is measured against incident ray)

Therefore, the above equation becomes

$$\frac{-I}{O} = \frac{-v}{-u} \text{ or } \frac{I}{O} = -\frac{v}{u} \dots (ii)$$

From the equations (i) and (ii), we have

$$m = \frac{I}{O} = -\frac{v}{u} \dots (iii)$$

Also by Mirror formula

$$\frac{1}{u} + \frac{1}{v} = \frac{1}{f}$$

Multiplying by v, we get

$$\frac{v}{u} + \frac{v}{v} = \frac{v}{f} \Rightarrow \frac{v}{u} = \frac{v}{f} - 1$$

$$\frac{v}{u} = \frac{v}{f} - 1 = \frac{v - f}{f}$$

So,

$$m = \frac{f - v}{f}$$

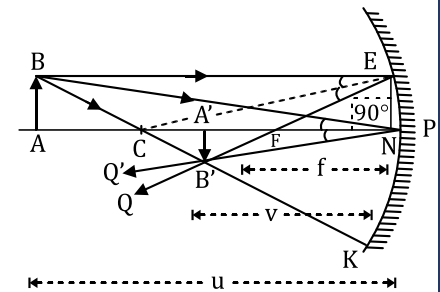



30. Refraction at Convex Spherical Surface

[3 marks, CBSE 2017, 18, 19, 20, 21, 23]

Let us consider a convex spherical refracting surface with

μ_2 = refractive index of medium 2 &

μ_1 = Refractive index of medium 1,

Let P = pole, C = center of curvature and

PC = Principal axis of the convex surface.

When object lies in the rarer medium and image formed is real.

O = Object. Draw AN as perpendicular and take angle α, β & γ respectively in triangles.

Let $\angle AOP = \alpha$; $\angle AIP = \beta$ and $\angle ACP = \gamma$.

In triangle AOC, we have

$$i = \alpha + \gamma \quad (\text{exterior angle property}) \quad \dots (i)$$

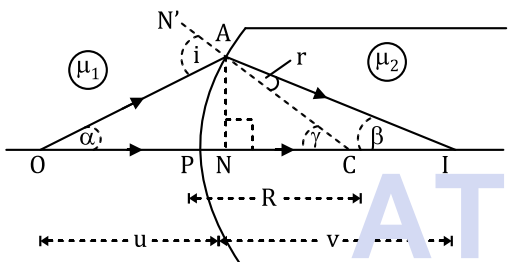

Since angles α, β and γ will be small. As such, these angles may be replaced by their $\tan \alpha$ etc.

Therefore, equation (i) may be written as

$$i = \tan \alpha + \tan \gamma \quad \dots (ii)$$

From right angled triangles ANO and ANC, we have

$$\tan \alpha = \frac{AN}{NO} \text{ and } \tan \gamma = \frac{AN}{NC}$$

In the equation (ii), substituting for $\tan \alpha$ and $\tan \alpha$, we have

$$i = \frac{AN}{NO} + \frac{AN}{NC} \quad \dots (iii)$$

$NO \approx PO$ and $NC \approx PC$

Therefore, the equation (iii) becomes

$$i = \frac{AN}{PO} + \frac{AN}{PC} \quad \dots (iv)$$

Now, from triangle ACI, $\gamma = r + \beta$ (by exterior angle property) or $r = \gamma - \beta$

Since angles β and γ are small, we have $r = \tan \gamma - \tan \beta \quad \dots (v)$

From right angled triangles ANC and ANI, we have

$$\tan \gamma = \frac{AN}{NC} \approx \frac{AN}{PC} \text{ and } \tan \beta = \frac{AN}{NI} \approx \frac{AN}{PI}$$

In the equation (v), substituting for $\tan \beta$ and $\tan \gamma$ we have

$$r = \frac{AN}{PC} - \frac{AN}{PI} \quad \dots (vi)$$

By Snell's law

$$\mu_1 \sin i = \mu_2 \sin r$$

Since the angles i and r are also small, the above equation becomes

$$\mu_1 i = \mu_2 r$$

From the equations (iv) and (vi), substituting the values of i and r , we have

$$\mu_1 \left(\frac{AN}{PO} + \frac{AN}{PC} \right) = \mu_2 \left(\frac{AN}{PC} - \frac{AN}{PI} \right)$$

$$\text{or } \frac{\mu_1}{PO} + \frac{\mu_1}{PC} = \frac{\mu_2}{PC} - \frac{\mu_2}{PI}$$

$$\text{or } \frac{\mu_1}{-u} + \frac{\mu_1}{PI} = \frac{\mu_2}{R} - \frac{\mu_2}{v} \quad \dots (vii)$$

Applying new cartesian sign conventions:

$PO = -u$ (object distance)

$PI = +v$ (image distance) and

$PC = +R$ (Radius of curvature)

Therefore, the equation (vii) becomes

$$\frac{\mu_1}{-u} + \frac{\mu_2}{+v} = \frac{\mu_2 - \mu_1}{+R} \text{ or } \boxed{\frac{\mu_2}{v} - \frac{\mu_1}{u} = \frac{\mu_2 - \mu_1}{R}}$$

31. Lens Maker's Formula

[3 marks, CBSE 2017, 18, 20, 21, 22]

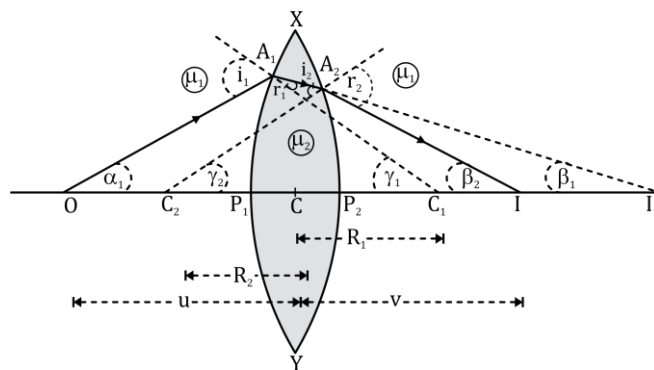

Let us consider a convex lens with refracting surface with

(Physics)

RAY OPTICS & OPTICAL INSTRUMENTS



μ_2 = refractive index of outer medium &
 μ_1 = Refractive index of lens ,

Suppose that O is a point object placed on the principal axis of the lens. The surface XP_1Y forms the real image I_1 (assuming that material of the lens extends beyond the face XP_1Y as such). It can be obtained* that

$$\frac{\mu_1}{P_1O} + \frac{\mu_2}{P_1I_1} = \frac{\mu_2 - \mu_1}{P_1C_1} \dots (i)$$

Since the lens is thin, the point P_1 lies very close to the optical centre C of the lens. Therefore, we may write

$$P_1O \approx CO; P_1I_1 \approx CI_1 \text{ and } P_1C_1 \approx CC_1$$

$$\text{So, } \frac{\mu_1}{CO} + \frac{\mu_2}{CI_1} = \frac{\mu_2 - \mu_1}{CC_1} \dots (ii)$$

The image formed by first refraction will act as virtual object for 2nd surface refraction.

$$-\frac{\mu_2}{P_2I_1} + \frac{\mu_1}{P_2I} = \frac{\mu_2 - \mu_1}{P_2C_2} \dots (iii)$$

Again $P_2I_1 \approx CI_1, P_2I \approx CI$ and $P_2C_2 \approx CC_2$

Therefore, eq (iii) may be written as

$$-\frac{\mu_2}{CI_1} + \frac{\mu_1}{CI} = \frac{\mu_2 - \mu_1}{CC_2} \dots (iv)$$

Adding the eq (ii) and (iv), we have

$$\frac{\mu_1}{CO} + \frac{\mu_2}{CI_1} - \frac{\mu_2}{CI_1} + \frac{\mu_1}{CI} = \frac{\mu_2 - \mu_1}{CC_1} + \frac{\mu_2 - \mu_1}{CC_2}$$

$$\text{or } \frac{\mu_1}{CO} + \frac{\mu_1}{CI} = (\mu_2 - \mu_1) \left(\frac{1}{CC_1} + \frac{1}{CC_2} \right) \dots (v)$$

Applying the new cartesian sign conventions:

$CO = -u$ (object distance)

$CI = +v$ (Final image distance)

$CC_1 = +R_1$ and $CC_2 = -R_2$ (Radii of curvature)

$$\frac{\mu_1}{-u} + \frac{\mu_1}{+v} = (\mu_2 - \mu_1) \left(\frac{1}{+R_1} + \frac{1}{-R_2} \right)$$

Dividing both sides of the above equation by μ_1 , we have

Since $\mu_2/\mu_1 = \mu$, we have

$$\frac{1}{v} - \frac{1}{u} = (\mu - 1) \left(\frac{1}{R_1} - \frac{1}{R_2} \right) \dots (vi)$$

Also if $u = CF_1 = -f_1$ (focal length), then $v = \infty$

Setting the above condition in the equation (vi), we have

$$-\frac{1}{-f_1} + \frac{1}{\infty} = (\mu - 1) \left(\frac{1}{R_1} - \frac{1}{R_2} \right)$$

$$\boxed{\frac{1}{f} = (\mu - 1) \left(\frac{1}{R_1} - \frac{1}{R_2} \right)} \dots (ix)$$

32. Refraction through a Prism

[3 marks, CBSE 2017, 18, 20, 21, 22]

KTS = δ is called the angle of deviation.

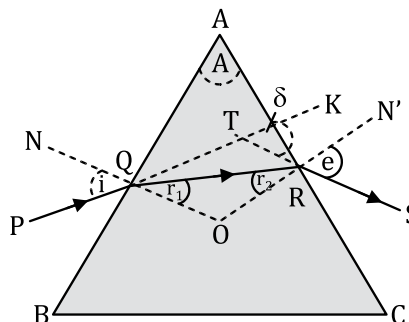

Since $\angle TQO = \angle NQP = i$ and $\angle RQO = r_1$, we have

$$\angle TQR = i - r_1$$

Also,

$\angle TRO = \angle NSE = e$ and $\angle QRO = r_2$. Therefore,

$$\angle TRQ = e - r_2$$

in triangle TQR, by exterior angle property

$$\delta = \angle TQR + \angle TRQ = (i - r_1) + (e - r_2)$$

$$\text{or } \delta = (i + e) - (r_1 + r_2) \dots (i)$$

In triangle QRO, the sum of the angles is 180° .

Therefore,

$$r_1 + r_2 + \angle QOR = 180^\circ \dots (ii)$$

In quadrilateral AQOR,

$$A + \angle QOR = 180^\circ \dots (iii)$$

From the equations (ii) and (iii), we have

$$r_1 + r_2 = A \dots (iv)$$

In the equation (i), substituting for $(r_1 + r_2)$ we have

$$\delta = (i + e) - A \dots (v)$$

Also, when $\delta = \delta_m$; (in minimum deviation position),

$$e = i \text{ and } r_2 = r_1 = r = A/2 \text{ (say)}$$

Also, setting $\delta = \delta_m$ and $e = i$ in the equation (v), we have

$$A + \delta_m = i + i \text{ or } i = (A + \delta_m)/2$$

The refractive index of the material (${}^a\mu_g$ or simply μ) of the prism is given by

$$\mu = \frac{\sin i}{\sin r}$$

$$\therefore \boxed{\mu = \frac{\sin(A + \delta_m)/2}{\sin A/2}}$$

(Physics)

RAY OPTICS & OPTICAL INSTRUMENTS



33. Simple Microscope (Magnifying Glass)

[3 marks, CBSE 2018, 22, 23]

A convex lens of short focal length can be used to see magnified image of a small object and is called a magnifying glass or a simple microscope.

So,

Magnifying power of simple microscope

$$= \frac{\text{Angle made by image on eye (when kept at } D)}{\text{Angle made by object on eye (when kept at } D)}$$

Let $\angle A'CB' = \beta$ be the angle subtended by the image at the eye. Cut $A'Q$ equal to AB (object size) and join QC . Then, $\angle A'CQ' = \alpha$ is the angle subtended by the object at the eye, when it is placed at the least distance of distinct vision.

By definition, the magnifying power of the simple microscope is given by

$$M = \frac{\beta}{\alpha}$$

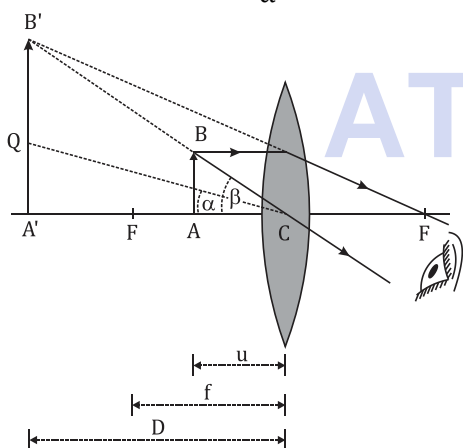

In practice, the angles α and β are small. Therefore, the angles α and β can be replaced by their tangents i.e.

$$M = \frac{\tan \beta}{\tan \alpha} \quad \dots (i)$$

From the right angled $\triangle CA'Q$,

$$\tan \alpha = \frac{A'Q}{CA'} = \frac{AB}{CA'} \quad (\because A'Q = AB)$$

Also, from the right angled $\triangle ABC$

$$\tan \beta = \frac{AB}{CA}$$

Substituting for $\tan \alpha$ and $\tan \beta$ in the equation we have

$$M = \frac{AB/CA}{AB/CA'} \text{ or } M = \frac{CA'}{CA} \quad \dots (ii)$$

Now, $CA = u$ and $CA' = D$

Therefore, the equation (ii) becomes

$$M = \frac{D}{u} \quad \dots (iii)$$

$$u = -u \text{ or } v = -D$$

33.a - Magnifying power- When image is formed at D (least distance of distinct vision=25cm).

Therefore, the above equation becomes by lens formula

$$-\frac{1}{-u} + \frac{1}{-D} = \frac{1}{f} \text{ or } \frac{1}{u} - \frac{1}{D} = \frac{1}{f}$$

$$\text{or } \frac{D}{u} - 1 = \frac{D}{f} \text{ or } \frac{D}{u} = 1 + \frac{D}{f} \quad \dots (iv)$$

From the equations (iii) and (iv), we have

$$M = 1 + \frac{D}{f} \quad \dots (v)$$

33.b - Magnifying power (When image is formed at infinity).

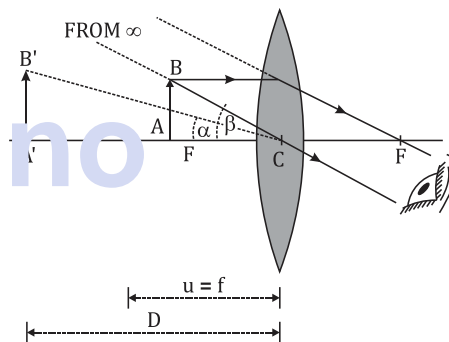

$$u = -f \text{ and } CA' = -D$$

(Note: Remember the first clear image is always seen at D only)

Therefore, the above equation gives

$$M = \frac{D}{u} = \frac{D}{f} \quad \dots (vii)$$

34. Compound Microscope

[3 marks, CBSE 2018, 20, 21]

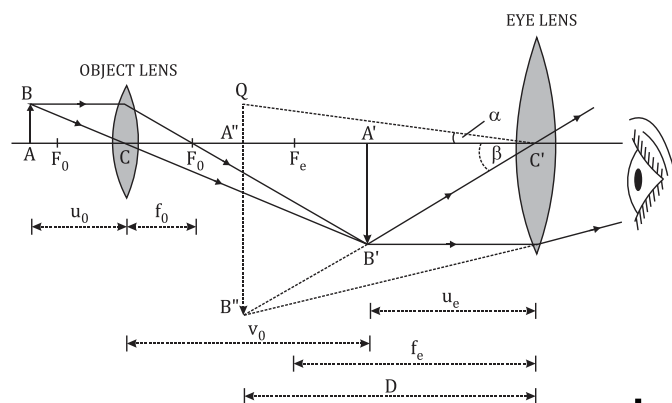

(Physics)

RAY OPTICS & OPTICAL INSTRUMENTS



For a compound microscope two lenses, eyepiece of focal length (f_e) and objective of focal length (f_o) are used to achieve greater magnification than simple microscope. *First clear image is formed at D (least distance of distinct vision = 25cm)*

So,

Magnifying power of Compound microscope

$$= \frac{\text{Angle made by image on eye (when kept at D)}}{\text{Angle made by object on eye (when kept at D)}}$$

Let $\angle A''C'B'' = \beta$ be the angle subtended by the image at the eye. extend $A''Q$ equal to AB (object size) and join QC . Then, $\angle A''C'Q = \alpha$ is the angle subtended by the object at the eye, when it is placed at the least distance of distinct vision.

By definition, the magnifying power of the simple microscope is given by

$$M = \frac{\beta}{\alpha}$$

Since the angles α and β are small, they can be replaced by their tangents i.e.

$$M = \frac{\tan \beta}{\tan \alpha} \quad \dots (i)$$

$$\text{Also } \tan \alpha = \frac{A''Q}{C'A''} = \frac{AB}{C'A''} \quad (\because A''Q = AB)$$

$$\text{Also, } \tan \beta = \frac{A''B''}{C'A''}$$

Multiplying and dividing by $A'B'$, we have

$$M = \frac{A''B''}{AB} \times \frac{A'B'}{A'B'} = \frac{A'B'}{AB} \times \frac{A''B''}{A'B'}$$

$$\text{Also } \frac{A'B'}{AB} = \frac{v_o}{u_o} = m_o = \text{magnification of object lens}$$

(v_o & u_o = Image & object dist. from object lens) &

$$\frac{A''B''}{A'B'} = \frac{v_e}{u_e} = m_e = \text{magnification of eye lens}$$

(v_e & u_e = Image & object distance from eye lens)

$$\text{So, } M = m_o \times m_e \quad \dots (ii)$$

34.a - Magnifying power - When image is formed at D (least distance of distinct vision).

Now, for the eye lens, the lens equation may be written as

$$-\frac{1}{u_e} + \frac{1}{v_e} = \frac{1}{f_e} \text{ or } \frac{v_e}{u_e} = 1 - \frac{v_e}{f_e}$$

So putting value for m_e we have,

$$m_e = 1 - \frac{v_e}{f_e} \dots \dots \dots (iii)$$

Applying the new Cartesian sign conventions:

$$v_e = -D \text{ and } f_e = +f_e$$

In the above equation, substituting for v_e and f_e , we have

$$m_e = 1 + \frac{D}{f_e} \quad \dots (iv)$$

So, putting values in $M = m_o \times m_e$ we get

$$M = \frac{v_o}{u_o} \left(1 + \frac{D}{f_e} \right) \quad \dots (vii)$$

34.b - Magnifying power - When image is formed at infinity.

We know, $M = m_o \times m_e$ & $m_o = \frac{v_o}{u_o}$ & $m_e = \frac{v_e}{u_e}$,

For image at infinity $u_e = -f_e$ & $v_e = -D$

Here f_e is the focal length of the eye lens.

(Note: Remember the first clear image is always seen at D only so $v_e = -D$)

$$\text{So, } M = \frac{v_o}{u_o} \times \frac{D}{f_e} \quad \dots (ix)$$

35. Astronomical Telescope (Refracting Type)

[3 marks, CBSE 2017, 18, 21]

An astronomical telescope is used to see the heavenly objects.

An astronomical telescope consists of two lens systems. The lens system facing the object is called objective. It has large aperture and is of large focal length (f_o). The other lens system is called eyepiece. It has small aperture and is of short focal length (f_e). *Also the first clear image is formed at D (least distance of distinct vision = 25cm)*

Magnifying power of refracting telescope

$$= \frac{\text{Angle made by image on eye (when kept at D)}}{\text{Actual angle of object on eye}}$$

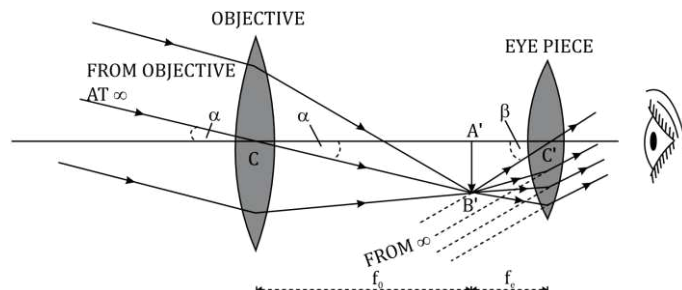

Thus, $\angle A'CB' = \alpha$ may be considered as the angle subtended by object at the eye.

Let $\angle A'C'B' = \beta$. Then, by definition,

$$M = \frac{\beta}{\alpha}$$

Since the angles α and β are small,

(Physics)

RAY OPTICS & OPTICAL INSTRUMENTS



$$\alpha \approx \tan \alpha \text{ and } \beta \approx \tan \beta$$

$$\therefore M = \frac{\tan \beta}{\tan \alpha} \quad \dots (i)$$

From the right angled $\triangle CA'B'$, $\tan \alpha = \frac{A'B'}{CA'}$

and from the right angled $\triangle C'A'B'$, $\tan \alpha = \frac{A'B'}{C'A'}$

In the equation (i), substituting for $\tan \alpha$ and $\tan \beta$, we have

$$M = \frac{A'B'/C'A'}{A'B'/CA'} = \frac{CA'}{C'A'} \quad \dots (ii)$$

Magnifying power - When image is formed at infinity .

(Note: Remember the first clear image is always seen at D only)

Applying the new cartesian sign conventions:

$$CA' = +f_o \text{ and } C'A' = -f_e$$

Substituting for CA' and $C'A'$ in the equation (ii), we have

$$M = -\frac{f_o}{f_e}$$



(Physics)

WAVE OPTICS



36. Laws of Reflection on Wave Theory

[3 marks, CBSE 2017, 18, 20]

Let ML be a beam of light that reflects back from surface XY.

Here PA is wave front for incident beam and P'A' is wave front for reflected beam. If c is velocity of light, then time taken (t) by light to go from the point P to P' and by light to go from A to A' will be same as both lie on wave fronts.

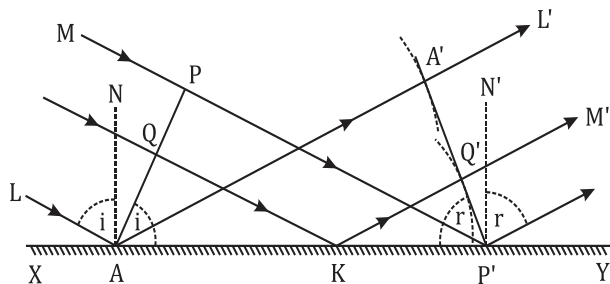

$\angle LAN = i, \angle NAA' = r$ (angle of reflection)

By using properties of complementary angle

$\angle PAP' = i, \angle AP'A' = r$

We have

$$\sin i = \frac{PP'}{AP'} \text{ \& \sin r = } \frac{AA'}{AP'} \text{ (i)}$$

Here $PP' = ct$ and $AA' = c't$

putting the values in (i)

$$\sin i = \frac{ct}{AP'} \text{ \& \sin r = } \frac{c't}{AP'}$$

so, $\sin i = \sin r$

$$\text{or } \boxed{i = r}$$

i.e. the angle of incidence is equal to the angle of reflection. (laws of reflection)

37. Refraction on The Basis of Wave Theory

[3 marks, CBSE 2017, 19, 21]

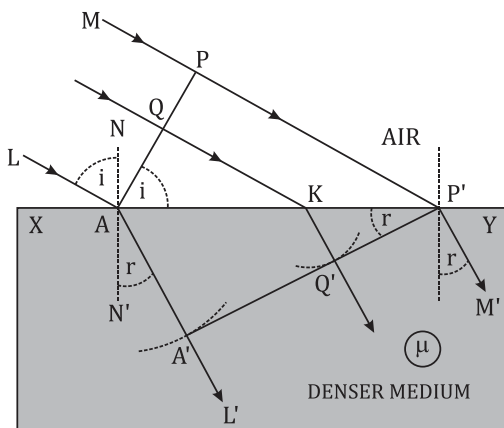

Let ML be a beam of light that refracts to second medium from XY boundary.

Here PA is wave front for incident beam and P'A' is wave front for refracted beam.

Let time taken (t) by light to go from the point P to P' and in same time let A reaches to A' after refraction.

$\angle LAN = i, \angle N'AA' = r$ (angle of refraction)

By using properties of complementary angle

$\angle PAP' = i, \angle AP'A' = r$

We have

$$\sin i = \frac{PP'}{AP'} \text{ \& \sin r = } \frac{AA'}{AP'} \text{ (i)}$$

Here $PP' = ct$ and $AA' = c't$

$c =$ speed of light in air

$c' =$ speed of light in denser medium

$$\mu = \frac{c}{c'} = \text{refractive index of denser medium (ii)}$$

so, from equation (i) & (ii)

$$\frac{\sin i}{\sin r} = \frac{PP'}{AA'} = \frac{ct}{c't} = \frac{c}{c'} = \mu$$

$$\boxed{\frac{\sin i}{\sin r} = \mu}$$

Hence, the laws of refraction (Snell's law) is proved on the basis of the wave theory.

38. Conditions for Constructive and Destructive Interference

[3 marks, CBSE 2017, 20, 22]

Let a source of monochromatic light S illuminates two narrow slits S_1 and S_2 . The two illuminated slits act as the two coherent sources. At the centre O of the screen, the intensity of light is maximum and it is called central maximum.

Condition for maximum and minimum.

Let the displacements of the waves from the sources S_1 and S_2 at point P on the screen at any time t be given by

$$y_1 = a_1 \sin \omega t$$

$$\text{and } y_2 = a_2 \sin(\omega t + \phi),$$

where ϕ is the constant phase difference between the two waves.

(Physics)

WAVE OPTICS



So superimposed wave will be

$$y = y_1 + y_2 = a_1 \sin \omega t + a_2 \sin(\omega t + \phi)$$

$$y = (a_1 + a_2 \cos \phi) \sin \omega t + a_2 \sin \phi \cos \omega t \dots (i)$$

Let $a_1 + a_2 \cos \phi = A \cos \theta \dots (ii)$
 and $a_2 \sin \phi = A \sin \theta \dots (iii)$

Then, the equation (i) becomes

$$y = A \cos \theta \sin \omega t + A \sin \theta \cos \omega t$$

or $y = A \sin(\omega t + \theta)$

Also Squaring and adding both sides of the equations (ii) and (iii), we obtain

$$A^2 \cos^2 \theta + A^2 \sin^2 \theta = (a_1 + a_2 \cos \phi)^2 + a_2^2 \sin^2 \phi$$

or $A^2 = a_1^2 + a_2^2$
 $(\cos^2 \phi + \sin^2 \phi) + 2a_1 a_2 \cos \phi$
 or $A^2 = a_1^2 + a_2^2 + 2a_1 a_2 \cos \phi \dots (iv)$

For constructive interference the intensity of light will be maximum so, $A = \max$

So, $\cos \phi = 1$

So, $\phi = \frac{2\pi}{\lambda} x = 2n\pi$, or $x = n\lambda$ where
 $n = 0, 1, 2, 3, \dots, n$

For Destructive interference.

From equation (iv) it follows that the intensity of light at point P will be minimum, if

$\cos \phi = -1$ or $\phi = \pi, 3\pi, 5\pi, \dots$
 or $\phi = (2n + 1)\pi$,

where $n = 0, 1, 2, \dots$

Also, from the equations (vi) and (viii), we have

$$\frac{2\pi}{\lambda} x = (2n + 1)\pi$$

or $x = (2n + 1) \frac{\lambda}{2}$

where $n = 0, 1, 2, \dots, n$

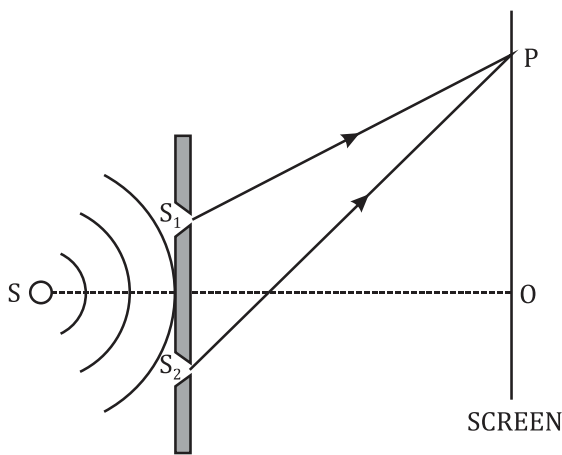

(Physics)

NUCLEI



41. Nuclear Density

Let ρ be the density of the nucleus of an atom, whose mass number is A.

mass of the nucleus of the atom of mass number A = A a.m.u. = $A \times 1.660565 \times 10^{-27}$ kg

If R is the radius of the nucleus, then

$$\begin{aligned} \text{volume of nucleus} &= \frac{4}{3}\pi R^3 = \frac{4}{3}\pi \left(R_0 A^{\frac{1}{3}}\right)^3 \\ &= \frac{4}{3}\pi R_0^3 A \end{aligned}$$

Taking $R_0 = 1.1 \times 10^{-15}$ m, we have

$$\text{volume of the nucleus} = \frac{4}{3}\pi(1.1 \times 10^{-15})^3 \times A \text{ m}^3$$

$$\text{Density of the nucleus, } \rho = \frac{\text{mass of nucleus}}{\text{volume of nucleus}}$$

$$= \frac{A \times 1.660565 \times 10^{-27}}{\frac{4}{3}\pi(1.1 \times 10^{-15})^3 \times A}$$

$$= 2.97 \times 10^{17} \text{ kg m}^{-3} \text{ (Independent of A)}$$

42. Mass Defect

[2 marks, CBSE 2017, 18, 20, 22, 23]

The difference between the sum of the masses of the nucleons constituting a nucleus and the rest mass of the nucleus is known as mass defect. It is denoted by Δm .

Let us calculate the mass defect in case of the nucleus of an atom ${}_Z X^A$. The nucleus of such an atom contains Z protons and (A-Z) neutrons.

Therefore,

$$\text{mass of the nucleons} = Zm_p + (A - Z)m_n$$

If $m_N({}_Z X^A)$ is mass of the nucleus of the atom ${}_Z X^A$, then the mass defect is given by

$$\Delta m = [Zm_p + (A - Z)m_n] - m_N({}_Z X^A) \dots (i)$$

Here,

$m_N({}_Z X^A)$ is mass of the nucleus of the atom ${}_Z X^A$.

m_p = mass of proton ,

m_n = mass of neutron

A = Mass number , Z = Atomic number

The mass defect can also be expressed in another form as explained below:

Adding and subtracting the mass of Z electrons i.e. Zm_e on the R.H.S. of equation (i), we have

$$\begin{aligned} \Delta m &= [Zm_p + (A - Z)m_n + Zm_e] - m_N({}_Z X^A) - Zm_e \\ &= [Z(m_p + m_e) + (A - Z)m_n] - [m_N({}_Z X^A) + Zm_e] \end{aligned}$$

Now, $m_p + m_e = m({}_1 H^1)$, mass of hydrogen atom

& $m_N({}_Z X^A) + Zm_e = m({}_Z X^A)$, mass of the atom ${}_Z X^A$

Therefore,

$$\Delta m = [Zm({}_1 H^1) + (A - Z)m_n] - m({}_Z X^A) \dots (ii)$$

43. Binding energy.

[2 marks, CBSE 2017, 19, 22, 23]

Thus, the binding energy of a nucleus may be defined as the energy equivalent to the mass defect of the nucleus.

If Δm is mass defect of a nucleus, then according to Einstein's energy relation, binding energy of the nucleus = Δmc^2 (in joule)

$$\text{Binding energy} = [Zm_p + (A - Z)m_n - m_N({}_Z X^A)] \times c^2$$

Here,

$m_N({}_Z X^A)$ is mass of the nucleus of the atom ${}_Z X^A$.

m_p = mass of proton ,

m_n = mass of neutron

A = Mass number , Z = Atomic number

1amu $\times c^2 = 931.5$ Mev (All masses are kept in amu)

The mass defect can also be expressed in another form:

$$\Delta m = [Zm({}_1 H^1) + (A - Z)m_n] - m({}_Z X^A)$$

$$\text{Binding energy} = [Zm({}_1 H^1) + (A - Z)m_n - m({}_Z X^A)] \times c^2$$

Here $m({}_1 H^1)$ = mass of hydrogen atom

$m({}_Z X^A)$ = mass of the atom ${}_Z X^A$