



# Aakash Model Test Papers (AMTP)

ATDB.uno

for CBSE Board Exams

Physics

Chemistry

Biology

Mathematics

Class  
**XII**

## Process:

1. A student must go through the **instructions** carefully and adhere strictly to them.
2. A student must finish answering the question paper of each subject in **stipulated time**.

## Benefits:

1. This booklet will help students to prepare for school examinations as it comprises of most relevant questions as per guidelines and paper pattern provided by CBSE.
2. These model test papers will help students to analyze where they stand and what additional efforts are required for further improvement in School/Board exams.

## Solutions:

After attempting the papers, a student must refer to the answers and solutions available on our website **www.aakash.ac.in**. To get the text solution, students are required to **sign in** their account with their login credentials.

# Contents

S.No.	Subject	Page No.
1.	Physics .....	01 – 28
2.	Chemistry .....	29 – 60
3.	Biology .....	61 – 90
4.	Mathematics .....	91 – 122

## ALL RIGHTS RESERVED

All rights including copyright and translation rights *etc.* reserved and vests exclusively with AESL. No part of this publication may be reproduced, distributed, redistributed, copied or transmitted in any form or by any means—graphical, electronic or mechanical methods including photocopying, recording, taping or stored on information retrieval systems of any nature or reproduced on any disc, tape, media, information software device, without the prior written permission of AESL. Breach of this condition is strictly illegal (civil as well as criminal) under the applicable Laws.

© Aakash Educational Services Limited [AESL]

# Model Test Papers

# PHYSICS

ATDB.uno





Time: 3 Hours

# Model Test Paper-1

for  
School/Board Exams

M.M.: 70

## PHYSICS

*Topics:* Complete Syllabus of Class XII**General Instructions:**

1. There are 35 questions in all. All questions are compulsory.
2. This question paper has five sections: Section-A, Section-B, Section-C, Section-D and section-E. All the sections are compulsory.
3. Section-A contains **18** MCQ of 1 mark each, Section-B contains **7** questions of **2** marks each, Section-C contains **5** questions of **3** marks each, Section-D contains **3** long questions of **5** marks each and Section-E contains **2** case study-based questions of 4 marks each.
4. There is no overall choice. However, an internal choice has been provided in section-B, Section-C, Section-D and section-E. You have to attempt only one of the choices in such question.
5. Use of calculators is not allowed.

### SECTION - A

1. Two point charges  $+2 \mu\text{C}$  and  $+6 \mu\text{C}$  repel each other with a force of 12 N. If a charge of  $-4 \mu\text{C}$  is given to each of them, the new force between them is **[1]**  
(1) 4 N (repulsive) (2) 4 N (attractive)  
(3) 12 N (repulsive) (4) 8 N (attractive)
2. If a positive charge is shifted from a low potential region to a high potential region, the electric potential energy will **[1]**  
(1) Increase  
(2) Decrease  
(3) Remain same  
(4) May increase or decrease

@AAKASH\_TEST\_PAPERS\_2024

Corporate Office : Aakash Tower, 8, Pusa Road, New Delhi-110005. Ph.: 011-47623456

(1)

## Physics (Class XII)

## Model Test Paper-1

3. The effective capacitance of combination between  $A$  and  $B$  as shown in the figure is [1]

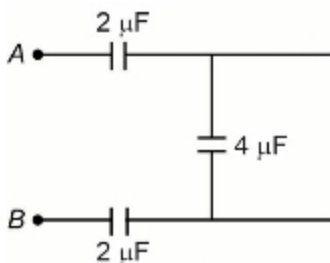

- (1)  $8 \mu\text{F}$  (2)  $4 \mu\text{F}$   
 (3)  $1 \mu\text{F}$  (4)  $\frac{4}{5} \mu\text{F}$
4. In the given circuit, current through  $1 \text{ ohm}$  resistor is [1]

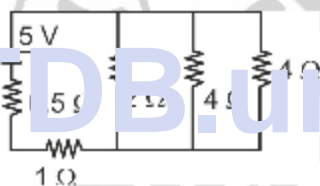

- (1) 2 A (2) 2.5 A  
 (3) 1 A (4) 1.5 A
5. In the given circuit, total power consumed is 200 W. The value of  $R$  is [1]

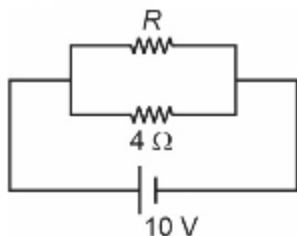

- (1)  $4 \Omega$  (2)  $7 \Omega$   
 (3)  $\frac{7}{5} \Omega$  (4)  $\frac{4}{7} \Omega$

@AAKASH\_TEST\_PAPERS\_2024

Corporate Office : Aakash Tower, 8, Pusa Road, New Delhi-110005. Ph.: 011-47623456

(2)

## Model Test Paper-1

## Physics (Class XII)

6. When a charged particle enters in a uniform magnetic field its kinetic energy [1]  
 (1) Remains constant (2) Increases  
 (3) Decreases (4) May increase or decrease
7. Same current  $i = 2$  A is flowing in a wire frame as shown in figure. The frame is placed in uniform magnetic field  $B = 4$  T which is in the plane of the frame. The magnitude of magnetic force acting on the frame is [1]

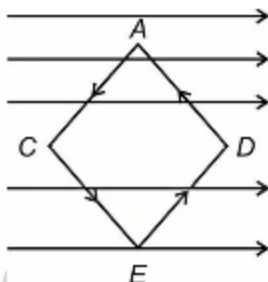

- (1) 48 N (2) 24 N  
 (3) 16 N (4) Zero
8. Which of the following is not an example of total internal reflection? [1]  
 (1) Working of optical fibre (2) Apparent and real depth  
 (3) Mirage (4) Brilliance of diamond
9. A photon of 12.09 eV is incident on a hydrogen atom having electron in ground state. Then the angular momentum of electron in the excited state will be [1]  
 (1)  $\frac{h}{2\pi}$  (2)  $\frac{2h}{2\pi}$   
 (3)  $\frac{3h}{2\pi}$  (4)  $\frac{4h}{2\pi}$
10. When light of wavelength 4000 Å is incident on a photosensitive surface of work function 2.0 eV, the kinetic energy of fastest electron is [1]  
 (1) 0.5 eV (2) 1.1 eV  
 (3) 2.1 eV (4) 3.1 eV

@AAKASH\_TEST\_PAPERS\_2024

Corporate Office : Aakash Tower, 8, Pusa Road, New Delhi-110005. Ph.: 011-47623456

(3)

## Physics (Class XII)

## Model Test Paper-1

11. Part of spectrum of electromagnetic radiations which is used to cook food is [1]
- (1) X-rays (2) Gamma-rays  
(3) Ultraviolet rays (4) Microwaves
12. 1 amu is equivalent to [1]
- (1) 931 MeV (2) 9.8 MeV  
(3) 9.31 MeV (4) 93.1 MeV
13. The expression of total energy of an electron in the orbit of hydrogen atom? [1]
- (1)  $-\frac{KZe^2}{2r^2}$  (2)  $-\frac{KZe^2}{2r}$   
(3)  $\frac{KZe^2}{2r}$  (4)  $\frac{KZe^2}{2r^2}$
14. The flow of current in conductor is due to movement of [1]
- (1) Holes (2) Electrons  
(3) Both (1) and (2) (4) None of these
15. The energy gap between the valence and conduction bands of a substance is 6 eV. The substance is a [1]
- (1) Conductor (2) Semiconductor  
(3) Insulator (4) Superconductor
16. **Assertion (A):** Electromagnetic waves can be deflected by magnetic or electric field. [1]
- Reason (R):** Electromagnetic waves consist of charged particles.
- (1) Both (A) and (R) are true and (R) is the correct explanation of (A).  
(2) Both (A) and (R) are true but (R) is not the correct explanation of (A).  
(3) (A) is true but (R) is false.  
(4) Both (A) and (R) are false.

@AAKASH\_TEST\_PAPERS\_2024

Corporate Office : Aakash Tower, 8, Pusa Road, New Delhi-110005. Ph.: 011-47623456

(4)

## Model Test Paper-1

## Physics (Class XII)

17. **Assertion:** Faraday's law of electromagnetic induction is a consequence of conservation of energy. [1]

**Reason:** In a purely resistive AC circuit, the current lags behind the emf in phase.

- (1) Both (A) and (R) are true and (R) is the correct explanation of (A).  
(2) Both (A) and (R) are true but (R) is not the correct explanation of (A).  
(3) (A) is true but (R) is false.  
(4) Both (A) and (R) are false.
18. **Assertion:** A charge, whether stationary or in motion produces electric field around it. [1]

**Reason:** Moving charge produces electric field as well as magnetic field in surrounding space.

- (1) Both (A) and (R) are true and (R) is the correct explanation of (A).  
(2) Both (A) and (R) are true but (R) is not the correct explanation of (A).  
(3) (A) is true but (R) is false.  
(4) Both (A) and (R) are false.

## SECTION - B

19. The bluish colour predominates in the clear sky, why? [2]

20. State Lenz's law.

A metallic rod held horizontally along east-west direction is allowed to fall under gravity, will there be an emf induced at its end? [2]

21. A steady current flows in a conductor of non-uniform cross-section. Which of the following quantities remain constant along the length of conductor: Current, drift speed, current density and electric field? [2]

OR

Calculate the average drift speed of conduction electrons in a copper wire of cross-sectional area  $1.0 \times 10^{-7} \text{ m}^2$ , carrying current of 1 A, free electron density is  $5.0 \times 10^{28} \text{ per m}^3$ . [2]

@AAKASH\_TEST\_PAPERS\_2024

Corporate Office : Aakash Tower, 8, Pusa Road, New Delhi-110005. Ph.: 011-47623456

(5)

## Physics (Class XII)

## Model Test Paper-1

22. Write the expression for magnetic force acting on a charge particle of charge  $q$ , moving with velocity  $\vec{v}$ , in a magnetic field  $\vec{B}$ . Show that no work is done by this force on the charged particle. [2]

OR

Two identical coils, each of radius  $R$ , are lying in perpendicular planes such that their centres coincide. Find the magnitude of magnetic field at the common centre of coils, if they carry currents  $I$  and  $\sqrt{3}I$  respectively. [2]

23. Derive the relation for magnetic energy stored in an inductor having inductance  $L$  and carrying current  $i$ . [2]
24. State Bohr's quantisation condition for defining stationary orbits. [2]
25. In the given circuit, calculate current in  $5\ \Omega$  resistance. [2]

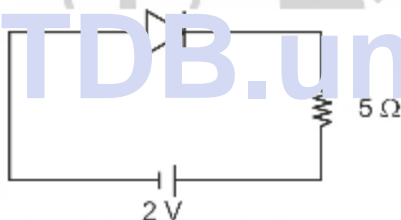

## SECTION - C

26. The electron in a given Bohr orbit has a total energy of  $-1.5\ \text{eV}$ . Calculate its [3]
- Kinetic energy
  - Potential energy
  - Wavelength of radiation emitted when the electron makes a transition to the ground state.
27. Derive the relation for magnetic moment of electron in an orbit, in terms of principal quantum number. [3]

@AAKASH\_TEST\_PAPERS\_2024

Corporate Office : Aakash Tower, 8, Pusa Road, New Delhi-110005. Ph.: 011-47623456

(6)

## Model Test Paper-1

## Physics (Class XII)

OR

Find the value of phase difference between the current and voltage in series LCR circuit as shown below. Which one leads in phase; voltage or current? [3]

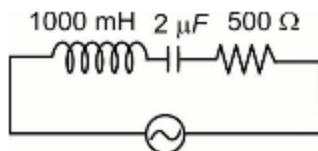

$$V = 200 \sin (1000t + \phi)$$

28. Monochromatic light of wavelength  $6000 \text{ \AA}$  is incident from air on water surface. Refractive index of water is  $\frac{4}{3}$ , find [3]
- Wavelength of refracted light
  - Speed of light in water
  - Frequency of refracted light

Draw a ray diagram to show the formation of image of an object placed on the axis of a convex refractive surface of radius of curvature  $R$ , separating two media of refractive indices  $n_1$  and  $n_2$ , consider the object placed in medium  $n_1$  and the convex surface is also towards medium  $n_1$ . By using this

diagram derive  $\frac{n_2}{v} - \frac{n_1}{u} = \frac{n_2 - n_1}{R}$  [3]

29. (a) The ratio of the width of two slits in Young's experiment is  $9 : 1$ . Calculate ratio of intensity of maxima and minima in interference pattern. [2]
- (b) Does the appearance of bright and dark fringe in interference pattern violate energy conservation law? [1]
30. When four hydrogen nuclei combine to form a helium nucleus, calculate the amount of energy released in the process of fusion. [3]

Given: Mass of  ${}^1_1\text{H}^1 = 1.007825 \text{ amu}$

Mass of  ${}^4_2\text{He}^4 = 4.002603 \text{ amu}$

Neglect mass of  $\beta$  particles.

@AAKASH\_TEST\_PAPERS\_2024

Corporate Office : Aakash Tower, 8, Pusa Road, New Delhi-110005. Ph.: 011-47623456

(7)

## SECTION - D

31. (a) Derive the relation for electric potential due to an electric dipole at its axial position. [3]
- (b) Four charges are placed on the vertices of a square of side 'a' as shown in figure. Calculate work done in moving a charge Q from centre of square to centre of one side. [2]

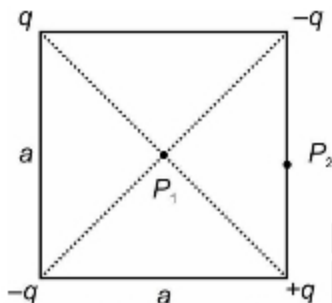

- (a) State Gauss's law. Find electric field due to uniformly charged thin spherical shell (Inside and outside) [3]
- (b) Five capacitors each of capacitance  $2 \mu\text{F}$  are connected in a circuit as shown in figure. If a DC source of  $7 \text{ V}$  is connected across  $AB$ , calculate energy stored in the network. [2]



32. Derive mirror equation with the help of concave mirror diagram. Using it, show that concave mirror forms virtual image of an object between pole and focus. [3+2]

OR

Draw the ray diagram for compound microscope when final image forms at least distance of vision and derive the relation for magnifying power, when final image forms at  $D$  (Least distance of distinct vision). [5]

## Model Test Paper-1

## Physics (Class XII)

33. Derive the expression for the torque acting on a rectangular current-carrying loop suspended in a uniform magnetic field. [5]

OR

- (a) State Faraday's law of electromagnetic induction. [2]
- (b) A metallic rod of length  $l$  is rotated at constant angular speed  $\omega$  about its one end, normal to a uniform magnetic field  $B$ . Derive the expression for the induced emf in the rod. [3]

## SECTION - E

34. Case study:

Read the following paragraph and answer the questions.

Equipotential surfaces are represented by curves for the various charge systems, while lines of force are represented by full line curves. We assume a constant potential difference between any two adjacent equipotential surfaces. The equipotential surfaces of a single point charge are concentric spherical shells with their centre at the point charge. Because line of force radiates outward, they are always perpendicular to equipotential surface.

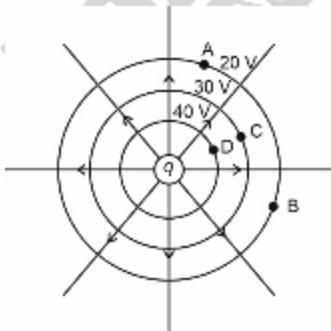

- (a) Calculate the work done to shift a unit charge from A to B along equipotential surface. [1]
- (b) Calculate the work done in shifting 1 coulomb of charge from point A to C. [1]

@AAKASH\_TEST\_PAPERS\_20

Corporate Office : Aakash Tower, 8, Pusa Road, New Delhi-110005. Ph.: 011-47623456

(9)

## Physics (Class XII)

## Model Test Paper-1

- (c) Prove that electric field lines are perpendicular to equipotential surface. [2]

OR

- (c) Electric potential at a point in space is given by  $V = 2x^2yz$  [2]  
Write the expression of electric field.

## 35. Case study:

Read the following paragraph and answer the question.

The total internal reflection of light is used in polishing diamonds to create a sparking brilliance. The diamond is made with specific cuts so that most of light rays incident at an angle greater than critical angle. Hence, they suffer multiple reflections and ultimately come out of diamond from the top. This gives the diamond a sparking brilliance.

- (a) The critical angle for a diamond is  $24.4^\circ$ . Then find its refractive index. [1]
- (b) A diamond is immersed in a liquid with refractive index greater than water. Then what is the impact on the critical angle for total internal reflection? [1]
- (c) Light cannot easily escape a diamond without multiple internal reflection. Specify the reason. [2]

OR

- (c) Define Snell's law. Using Snell's law derive the expression of critical angle. [2]

□ □ □

@AAKASH\_TEST\_PAPERS\_2024

Corporate Office : Aakash Tower, 8, Pusa Road, New Delhi-110005. Ph.: 011-47623456

(10)

Time: 3 Hours

# Model Test Paper-2

## for

### School/Board Exams

M.M.: 70

## PHYSICS

**Topics:** Complete Syllabus of Class XII

### General Instructions:

1. There are 35 questions in all. All questions are compulsory.
2. This question paper has five sections: Section-A, Section-B, Section-C, Section-D and section-E. All the sections are compulsory.
3. Section-A contains **18** MCQ of 1 mark each, Section-B contains **7** questions of 2 marks each, Section-C contains **5** questions of 3 marks each, Section-D contains **3** long questions of 5 marks each and Section-E contains **2** case study-based questions of 4 marks each.
4. There is no overall choice. However, an internal choice has been provided in section-B, Section-C, Section-D and section-E. You have to attempt only one of the choices in such a question.
5. Use of calculators is not allowed.

## SECTION - A

1. Three charges  $2q$ ,  $-q$  and  $-q$  are located at the vertices of an equilateral triangle. At the centre of triangle [1]
  - (1) Electric field is zero but potential is non zero.
  - (2) The electric field is non-zero but potential is zero.
  - (3) Both electric field and potential are zero.
  - (4) Both electric field and potential are non-zero.
2. A dipole having dipole moment  $\vec{P}$  is placed in uniform electric field  $\vec{E}$ . Then the torque acting on dipole is [1]
  - (1)  $\vec{\tau} = \vec{P} \times \vec{E}$
  - (2)  $\tau = \vec{P} \cdot \vec{E}$
  - (3)  $\vec{\tau} = -\vec{P} \times \vec{E}$
  - (4)  $\vec{\tau} = \vec{P} \cdot \vec{E}$

Corporate Office : Aakash Tower, 8, Pusa Road, New Delhi-110005. Ph.: 011-47623456

(11)

## Physics (Class XII)

## Model Test Paper-2

3. A combination of capacitors is made by stacking 5 equally spaced parallel plates connected alternatively. If the capacitance between two alternative plate is  $C$ , then resulting capacitance of system is [1]



- (1)  $C$  (2)  $2C$   
(3)  $3C$  (4)  $4C$
4. A wire of a certain material is stretched by 10%. Its new resistance and specific resistance become respectively [1]  
(1) Both remain same (2) 1.1 times, 1.21 times  
(3) 1.21 times, remain same (4) 1.21 times, 1.1 times
5. Full-scale deflection current of a galvanometer of resistance  $25 \Omega$  is 50 mA. The resistance required in series to convert it into voltmeter of 100 V is [1]  
(1)  $1975 \Omega$  (2)  $2000 \Omega$   
(3)  $1875 \Omega$  (4)  $4200 \Omega$
6. The flux linked with a coil at any instant  $t$  is given by  $\phi = (10t^2 - 50t)$ . The induced emf at  $t = 2$  s is [1]  
(1) 50 V (2) 20 V  
(3) 30 V (4) 10 V
7. With the increase in frequency of applied AC voltage capacitive reactance of a capacitor [1]  
(1) Decreases (2) Increases  
(3) First decreases then increases (4) First increases then decreases
8. If an electron and a proton have same de Broglie wavelength, then kinetic energy of electron is [1]  
(1) Less than that of a proton  
(2) More than that of a proton  
(3) Equal to that of a proton  
(4) May be less or equal to that of proton

## Model Test Paper-2

## Physics (Class XII)

9. If 'a' is the radius of the first Bohr orbit in a hydrogen atom, then the radius of third orbit is [1]
- (1) 3a (2) 6a  
(3) 9a (4) 27a
10. The ratio of radius of two nuclei of mass number  $A_1$  and  $A_2$  is [1]
- (1)  $\left(\frac{A_1}{A_2}\right)^{1/3}$  (2)  $\left(\frac{A_2}{A_1}\right)^{2/3}$   
(3)  $\left(\frac{A_1}{A_2}\right)^{1/2}$  (4)  $\left(\frac{A_2}{A_1}\right)^{1/2}$
11. A nucleus of mass number A has mass defect  $\Delta m$ . What is the formula for the binding energy per nucleon of this nucleus? [1]
- (1)  $\frac{\Delta mc^2}{A}$  (2)  $\frac{\Delta m^2 c}{A}$   
(3)  $\frac{\Delta mc}{A}$  (4)  $(\Delta mc^2)A$
12. What is the unit of power of a lens? [1]
- (1) meter (2) dioptre  
(3) centimetre (4) millimetre
13. In a full-wave rectifier, what is the output frequency, if the input frequency is 50 Hz. [1]
- (1) 25 Hz (2) 50 Hz  
(3) 75Hz (4) 100 Hz
14. Which of the following have shortest wavelength? [1]
- (1) X-rays (2) Ultraviolet rays  
(3) Microwaves (4) Infrared waves

## Physics (Class XII)

## Model Test Paper-2

15. The value of current in the given figure is [1]

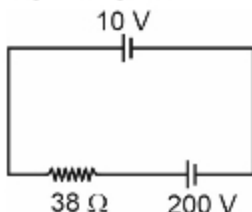

- (1) 10 A (2) 15 A  
(3) 4 A (4) 5 A
16. **Assertion:** In a non-uniform electric field, a dipole will have translatory as well as rotatory motion. [1]

**Reason:** In non-uniform electric field, dipole experiences a force as well as torque.

- (1) Both A and R are true and R is the correct explanation of A.  
(2) Both A and R are true but R is not the correct explanation of A.  
(3) A is true but R is false.  
(4) A is false and R is also false.
17. **Assertion:** Magnetic field lines can be entirely confined within the core of a toroid but not a straight solenoid. [1]

**Reason:** In a straight solenoid, the magnetic field lines cannot form closed loops within the solenoid.

- (1) Both A and R are true and R is the correct explanation of A.  
(2) Both A and R are true but R is not the correct explanation of A.  
(3) A is true but R is false.  
(4) A is false and R is also false.
18. **Assertion:** Electric field lines cross each other. [1]

**Reason:** Electric field at a point superimpose to give two resultants

- (1) Both A and R are true and R is the correct explanation of A.  
(2) Both A and R are true but R is not the correct explanation of A.  
(3) A is true but R is false.  
(4) A is false and R is also false. @AAKASH\_TEST\_PAPERS\_2024

## Model Test Paper-2

## Physics (Class XII)

## SECTION - B

19. State the essential condition for the phenomenon of total internal reflection of light to take place. [2]
20. (a) What is the phase difference between electric field vector and magnetic field vector in an electromagnetic wave? [1]  
 (b) Define equipotential surface. [1]
21. How are the electric vector  $\vec{E}$ , magnetic vector  $\vec{B}$  and velocity of light  $\vec{C}$  oriented in an electromagnetic wave? Write the relation between  $C$ ,  $E$  and  $B$ . [2]

OR

A conducting ring of radius  $r$ , is placed perpendicularly, in a time-varying magnetic field given by  $B = B_0 + \alpha t$ , where  $B_0$  and  $\alpha$  are constants. Calculate emf induced in the ring.

22. If the galvanometer in the given circuit reads zero, find the value of unknown resistance  $R$ . [2]

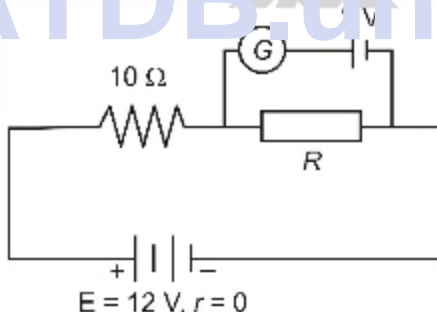

OR

Obtain an expression for the self-inductance of a solenoid having length  $l$ , number of turns  $N$  and area of each turn  $A$ .

23. State any two Bohr's postulates of hydrogen atom. [2]
24. Write Einstein's photoelectric equation and point out any two characteristic properties of photons on which this equation is based. [2]
25. With the help of circuit diagram, explain working of half-wave rectifier. [2]

## SECTION - C

26. State Gauss's law of electrostatics. Using this theorem, derive an expression for the electric field at any point due to an infinite plane sheet of uniform charge density  $\sigma$  C/m<sup>2</sup>. [3]
27. A convex lens of focal length 20 cm is placed coaxially with a convex mirror of radius of curvature 20 cm. The distance between lens and mirror is 15 cm and lens is placed in front of the mirror. A point object is placed at 40 cm in front of convex lens. Find the position of image after the reflection from the mirror. [3]
28. In a series resonant LCR circuit, the potential drop across  $R$  is 100 V and  $R = 1$  k $\Omega$ ,  $C = 2$   $\mu$ F. The resonant frequency  $\omega$  is 200 rad/s. Find the potential drop across inductor. [3]
29. Prove that magnifying power of astronomical telescope in normal adjustments is  $M = -\frac{f_o}{f_e}$  where  $f_o$  is focal length of objective and  $f_e$  is focal length of eyepiece. [3]

OR

In Young's double-slit experiment, define fringe width and derive its relation. What will be the effect on contrast of fringe, if size of both the slits are different?

30. (a) Find the potential difference ( $V_A - V_B$ ) between the point  $A$  and  $B$  in the given figure. [2]

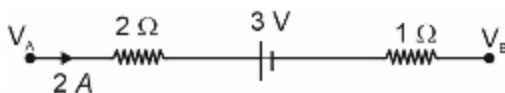

- (b) Which conservation law Kirchhoff's loop rule is based on? [1]

## Model Test Paper-2

## Physics (Class XII)

## SECTION - D

31. (a) Draw ray diagram of compound microscope when final image forms at least distance of vision. [2½]
- (b) A compound microscope has lenses of focal length 10 mm and 30 mm as objective and eyepiece respectively. The final image of an object placed at 1.2 cm from the objective lens is observed at 0.25 m from the eyepiece lens. Calculate distance between the two lenses. [2½]
32. (a)  $A$  and  $B$  are two concentric hollow metallic shells of radius  $R_A$  and  $R_B$ .  $A$  is given a charge  $Q_A$  while  $B$  is given a charge  $Q_B$ . Find the electric potential at a distance  $R$  from its centre such that [2½]

(i)  $R < R_A$

(ii)  $R > R_B$

- (b) Calculate electric field on axis of a uniformly charged ring having charge  $Q$ , radius  $R$ , at a distance  $x$  from the centre. [2½]

OR

- (a) Find the equivalent capacitance of the combination between  $A$  and  $B$  in the figure. [3]

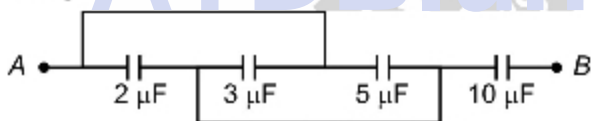

- (b) Write the formula of capacitance of parallel plate capacitor. Also write the formula of energy stored in capacitor in terms of charge  $q$ . [2]
33. (a) Using Biot-Savart's law derive an expression of magnetic field at the centre of circular coil. [2½]
- (b) A long straight solid metal wire of radius  $R$  carries a current  $I$ , uniformly distributed over its circular cross-section. Find the magnetic field at a distance  $r$  from axis of wire (i) inside and (ii) outside the wire. [2½]

OR

- (a) A capacitor, a resistor of  $5 \Omega$  and an inductor of 50 mH are in series with an A.C. source marked 100 V, 50 Hz. It is found that voltage is in phase with the current. Calculate the capacitance of the capacitor. [2½]
- (b) Define step-up and step-down transformer. [2½]

## SECTION - E

34. de Broglie hypothesis has shown that wave particle duality was not only a behaviour of light but was a fundamental principle exhibited by both radiation and matter. It is possible to use wave equation to describe material behaviour, so long as one properly applies the de Broglie wavelength. Though the de Broglie hypothesize wavelength of matter of any size, there are realistic limits only when it's useful. A cricket ball shot towards the boundary has de Broglie wavelength smaller than the diameter of a proton by about 20 orders of magnitude.
- (a) If the velocity of an electron is doubled then how will its de Broglie wavelength vary? [1]
- (b) Two cars A and B are moving. Car A is moving with speed  $v$  having de Broglie wavelength  $\lambda$ . Car B is moving with twice the speed of car A having kinetic energy twice that of car A. What will be the de Broglie wavelength of car B? [2]
- (c) A cricket ball of 50 g is moving with velocity  $1 \text{ m/s}$ . Find de Broglie wavelength of the ball. [1]
35. The current-voltage graph of junction diode is non-linear, which means it does not obey Ohm's law. The resistance of the junction diode varies with applied voltage. In such cases it is useful to define a quantity which is known as dynamic resistance. It is the ratio of small voltage change to the corresponding change in current.
- (a) Write expression of AC resistance of a forward-biased  $p$ - $n$  junction diode. [1]
- (b) When  $p$ - $n$  junction is reverse biased, what happens to motion of holes and electrons? [1]
- (c) What is the order of current in forward and reverse biasing? [2]
- OR**
- (c) Define forward and reverse biasing of  $p$ - $n$  junction diode [2]



## Model Test Paper-3

## Physics (Class XII)

Time: 3 Hours

**Model Test Paper-3**  
for  
School/Board Exams

M.M.: 70

**PHYSICS****Topics:** Complete Syllabus of Class XII**General Instructions:**

1. There are 35 questions in all. All questions are compulsory.
2. This question paper has five sections: Section-A, Section-B, Section-C, Section-D and section-E. All the sections are compulsory.
3. Section-A contains **18** MCQ of 1 mark each, Section-B contains **7** questions of **2** marks each, Section-C contains **5** questions of **3** marks each, Section-D contains **3** long questions of **5** marks each and Section-E contains **2** case study-based questions of 4 marks each.
4. There is no overall choice. However, an internal choice has been provided in section-B, Section-C, Section-D and section-E. You have to attempt only one of the choices in such a question.
5. Use of calculators is not allowed.

**SECTION - A**

1. If a body gives out  $10^9$  electrons every second, how much time is required to get total charge of 1C from it? **[1]**  
(1)  $6.25 \times 10^5$  s (2)  $6.25 \times 10^9$  s  
(3)  $3.25 \times 10^7$  s (4)  $3.25 \times 10^{11}$  s
2. The dimensional formula of electric flux is **[1]**  
(1)  $[M^1L^2T^{-2}A^{-1}]$   
(2)  $[M^{-1}L^3T^{-3}A]$   
(3)  $[M^1L^3T^{-3}A^{-1}]$   
(4)  $[M^1L^{-3}T^{-3}A^{-1}]$

@AAKASH\_TEST\_PAPERS\_2024

Corporate Office : Aakash Tower, 8, Pusa Road, New Delhi-110005. Ph.: 011-47623456

(19)

## Physics (Class XII)

## Model Test Paper-3

3. The relation between relative permeability ( $\mu_r$ ) and susceptibility ( $\chi$ ) of a material is [1]
- (1)  $\mu_r = \chi$
  - (2)  $\mu_r = 1 + \chi$
  - (3)  $\mu_r = \chi - 1$
  - (4)  $\mu_r = 1 + \chi^2$
4. An electron is moving at a speed of 100 m/s along the positive x-axis undeflected through uniform electric and magnetic field. The magnetic field is directed along positive z-axis and has magnitude 5.0 T. In unit vector notation, what is the electric field? [1]
- (1)  $\left(100 \frac{\text{V}}{\text{m}}\right) \hat{j}$
  - (2)  $\left(-100 \frac{\text{V}}{\text{m}}\right) \hat{k}$
  - (3)  $\left(-500 \frac{\text{V}}{\text{m}}\right) \hat{i}$
  - (4)  $\left(500 \frac{\text{V}}{\text{m}}\right) \hat{j}$
5. When an object placed between focal length ( $f$ ) and centre of curvature ( $C$ ) of a concave mirror, the image formed would be [1]
- (1) Virtual and magnified
  - (2) Real and diminished
  - (3) Real and magnified
  - (4) Virtual and diminished
6. The type of wavefront that will emerge from a point light source will be [1]
- (1) Spherical
  - (2) Elliptical
  - (3) Cylindrical
  - (4) Paraboloidal

@AAKASH\_TEST\_PAPERS\_2024

Corporate Office : Aakash Tower, 8, Pusa Road, New Delhi-110005. Ph.: 011-47623456  
(20)



## Physics (Class XII)

## Model Test Paper-3

11. In a Wheatstone bridge, three resistors  $P$ ,  $Q$  and  $R$  are connected in the three arms and the fourth arm is formed by two resistances  $S_1$  and  $S_2$  connected in parallel. The condition for the bridge to be balanced will be [1]

$$(1) \frac{P}{Q} = \frac{2S}{S_1 + S_2} \qquad (2) \frac{P}{Q} = \frac{R(S_1 + S_2)}{S_1 S_2}$$

$$(3) \frac{P}{Q} = \frac{R(S_1 + S_2)}{2S_1 S_2} \qquad (4) \frac{P}{Q} = \frac{R}{S_1 S_2}$$

12. Which one of the following represents forward-biased circuit? [1]



13. Magnetic field due to long current carrying wire at distance  $r$  (where  $i$  is the current) [1]

$$(1) \frac{\mu_0 i}{2\pi r} \qquad (2) \frac{\mu_0 i}{4\pi r}$$

$$(3) \frac{\mu_0 i}{2r} \qquad (4) \frac{\mu_0 i}{8\pi r}$$

14. What is the value of self-inductance of a coil if the current in it changes from 10 A to 2 A in 0.1 second and induced emf is 3.20 V? [1]

$$(1) 0.02 \text{ H} \qquad (2) 0.04 \text{ H}$$

$$(3) 0.08 \text{ H} \qquad (4) 0.01 \text{ H}$$

15. An electron and a proton have the same de Broglie's wavelength of 1 nm. The ratio of their momentum is [1]

$$(1) 1 : 1 \qquad (2) 2 : 1$$

$$(3) 1 : 2 \qquad (4) 1 : 4$$

@Aakash\_TEST\_PAPERS\_2024

## Model Test Paper-3

## Physics (Class XII)

16. **Assertion (A):** Magnet poles cannot be separated by dividing them into two parts. [1]

**Reason (R):** When a magnet is broken into two equal parts, the magnetic moment is decreased by half.

- (1) Both (A) and (R) are true and (R) is the correct explanation of (A).  
(2) Both (A) and (R) are true but (R) is not the correct explanation of (A).  
(3) (A) is true but (R) is false.  
(4) (A) is false and (R) is also false.
17. **Assertion (A):** The image of a point object situated at the centre of hemispherical lens is also formed at the centre. [1]

**Reason (R):** For hemispherical surfaces Snell's law is not valid.

- (1) Both (A) and (R) are true and (R) is the correct explanation of (A).  
(2) Both (A) and (R) are true but (R) is not the correct explanation of (A).  
(3) (A) is true but (R) is false.  
(4) (A) is false and (R) is also false.
18. **Assertion (A) :** The focal length of an equiconvex lens of radius of curvature  $R$  made of material of refractor index  $\mu = 1.5$  is  $R$ . [1]

**Reason (R) :** The focal length of lens is always  $\frac{R}{2}$ .

- (1) Both (A) and (R) are true and (R) is the correct explanation of (A).  
(2) Both (A) and (R) are true but (R) is not the correct explanation of (A).  
(3) (A) is true but (R) is false.  
(4) (A) is false and (R) is also false.

## SECTION - B

19. (i) When monochromatic light travels from one medium to another its wavelength changes while frequency remains same. Explain. [1]  
(ii) State Huygen's statement regarding formation of wavelets of light. [1]

## Physics (Class XII)

## Model Test Paper-3

20. What happens to the width of depletion layer of  $p$ - $n$  junction when it is [2]  
(i) Forward biased (ii) Reverse biased

OR

How is the radius of a nucleus related to its mass number  $A$ ? [2]

21. How does the fringe width of interference pattern change if the whole apparatus of Young's double-slit experiment is shifted from air to a liquid of refractive index 1.3? [2]
22. Draw energy band diagrams of an  $n$ -type semiconductor at  $T > 0$  K, mark the donor energy level with their energies. [2]
23. An AC voltage of 100 V, 50 Hz is connected across a  $20 \Omega$  resistor and 2 mH inductor in series. Calculate  
(i) Impedance of the circuit  
(ii) rms current in the circuit [2]

OR

Derive an expression for the resistivity of a good conductor, in terms of the relaxation time of electrons. [2]

24. Two point charges  $q$  and  $-2q$  are kept ' $d$ ' distance apart. Find the location of point relative to charge ' $q$ ' at which potential due to this system of charges is zero. [2]
25. An infinite number of charges, each of  $q$  coulomb, are placed along  $x$ -axis at  $x = 1$  m, 3 m, 9 m and so on. Calculate the electric field at the point  $x = 0$ , due to these charges if all the charges are of same sign. [2]

## SECTION - C

26. (i) State Gauss's law in electrostatics. [1]  
(ii) Using this law, derive an expression for electric field due to a long infinite wire. [2]
27. A 12 pF capacitor is connected to a 50 V battery. How much electrostatic potential energy is stored in the capacitor? If another capacitor of 6 pF is connected in series with it with the same battery connected across the combination, find the charge stored and potential difference across each capacitor. [3]

@AAKASH\_TEST\_PAPERS\_20

Corporate Office : Aakash Tower, 8, Pusa Road, New Delhi-110005. Ph.: 011-47623456

(24)

## Model Test Paper-3

## Physics (Class XII)

28. Show with the help of diagram, the behaviour of magnetic field lines in the presence of

- (i) Paramagnetic substances [1]  
(ii) Diamagnetic substances.

How does one explain this distinguishing feature? [2]

OR

Define self-inductance of a coil. Write its SI unit. Derive the expression for self-inductance of a long solenoid of cross-sectional area 'A' length 'l' having 'n' turn per unit length. [3]

29. Discuss briefly how wave theory of light cannot explain photoelectric effect. [3]

30. Draw the circuit diagram of a full-wave rectifier and state how it works. [3]

SECTION - I

31. (a) Define torque acting on a dipole of dipole moment  $\vec{P}$  placed in a uniform electric field  $\vec{E}$ . Express it in the vector form and point out the direction along which it acts. [2]

(b) What happens if the field is non-uniform? [1]

(c) What would happen if the external field  $\vec{E}$  is increasing (i) parallel to  $\vec{P}$  and (ii) anti-parallel to  $\vec{P}$ ? [2]

32. (a) State the underlying principle of working of a moving coil galvanometer.

Give a reason why a galvanometer cannot be used as it is to measure current in a circuit. Name any two factors on which the current sensitivity of a galvanometer depends. @AAKASH\_TEST\_PAPERS\_20[3]

Corporate Office : Aakash Tower, 8, Pusa Road, New Delhi-110005. Ph.: 011-47623456  
(25)

## Physics (Class XII)

## Model Test Paper-3

- (b) A moving coil galvanometer of resistance  $G$ , gives its full-scale deflection when a current  $I_G$  flows through its coil. It can be converted into an ammeter of range 0 to  $I$  ( $I > I_G$ ) when a shunt of resistance  $S$  is connected across its coil. If this galvanometer is converted into an ammeter of range 0 to  $2I$ , find the expression for the shunt required in terms of  $I_G$  and  $G$ . [2]

OR

- (a) Draw a labeled ray diagram showing the formation of a final image by a compound microscope at least distance of distinct vision. [2]
- (b) The total magnification produced by a compound microscope in near point adjustment is 20. The magnification produced by the eye piece is 5. The microscope is focused on a certain object. The distance between the objective and eyepiece is observed to be 14 cm. If least distance of distinct vision is 20 cm, calculate the focal length of the objective and the eye piece. [3]

33. In the given figure, calculate the following parameters.

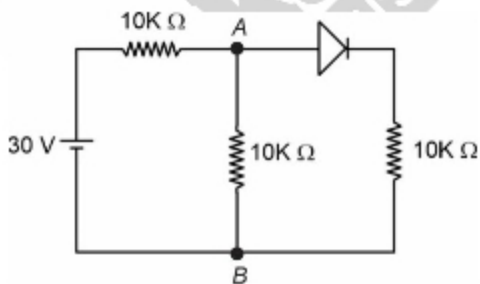

- (a) Draw the equivalent electrical circuit, considering diode as ideal. [1]
- (b) Equivalent resistance across the battery. [1]
- (c) Current flowing through the battery [1]
- (d) Potential difference across point A and B. [1]
- (e) The current flowing through diode. [1]

@AAKASH\_TEST\_PAPERS\_2024

Corporate Office : Aakash Tower, 8, Pusa Road, New Delhi-110005. Ph.: 011-47623456

(26)

## Model Test Paper-3

## Physics (Class XII)

## SECTION - E

34. Bohr's model explains the spectral lines of hydrogen atomic emission spectrum. While the electron of the atom remains in the ground state, its energy remains unchanged. When the atom absorbs one or more quanta of energy, the electron moves from the ground state orbit to an excited state orbit that is further away from the nucleus.

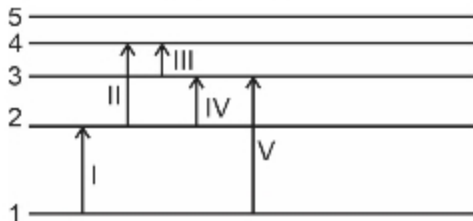

The given figure shows an energy level diagram of the hydrogen atom. Several transitions are marked as I, II, III and so on. The diagram is only indicative and not to scale.

- (i) In which transition or transitions a Balmer series photon absorbed? [1]  
 (ii) What is the wavelength of radiation involved in transition II? [1]  
 (iii) Which transition will occur when a hydrogen atom is irradiated with radiation of wavelength 103 nm? [1]  
 (iv) Find longest wavelength of Balmer series. [1]

OR

Find shortest possible wavelength of Lyman series.

35. A half wave rectifier is a type of rectifier that only allows one half-cycle of an AC voltage waveform to pass, blocking the other half-cycle. Halfwave rectifiers are used to convert AC voltage to DC voltage, and only require a single diode to construct. A half wave rectifier is the simplest form of rectifier available. Figure given below shows the input AC voltage waveform, the circuit diagram and the final output voltage waveform of a half wave rectifier. During the positive half cycle, the diode is forward biased making the current flow through the load resistor. While during the Negative half cycle the diode is reverse biased so it stops the current flow through the load resistor. Since

## Physics (Class XII)

## Model Test Paper-3

current cannot flow through the load during the negative half cycles, the output voltage is equal to zero.

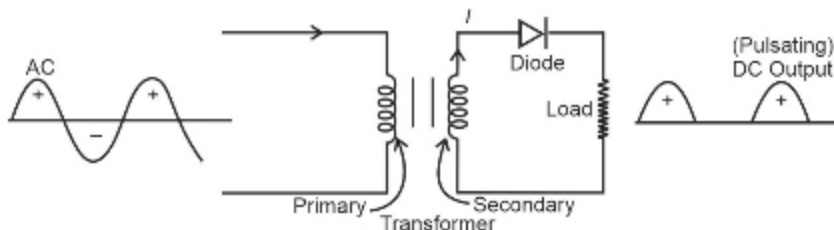

Figure: Half wave rectifier circuit diagram and waveform

$$V_0(t) = \begin{cases} V_m \sin(\omega t) & 0 \leq t \leq T/2 \\ 0 & T/2 \leq t \leq T \end{cases}$$

- (a) What is the average value of output voltage of half wave rectifier [1]
- (b) What is rms of the output voltage of half wave rectifier? [1]
- (c) Form factor (f.f.) is defined as the ratio between RMS load voltage and average load voltage. The form factor of the half wave rectifier is as [1]
- (1) 1.57 (2) 2.7
- (3) 3.14 (4) 1.75
- (d) If the frequency of the input signal is  $f$  then what is the frequency of output signal of half wave rectifier? [1]
- (1)  $f$  (2)  $2f$
- (3)  $\frac{f}{2}$  (4) Zero



# Model Test Papers

# CHEMISTRY

ATDB.uno



@AAKASH\_TEST\_PAPERS\_2024



ATDB.uno

@AAKASH\_TEST\_PAPERS\_2024

## Model Test Paper-1

## Chemistry (Class XII)

Time: 3 Hours

# Model Test Paper-1

## for

### School/Board Exams

M.M.: 70

## CHEMISTRY

**Topics:** Complete Syllabus of Class XII

### General Instructions:

1. There are **35** questions in this question paper with internal choice.
2. Section-A consists of **18** multiple-choice questions carrying **1** mark each.
3. Section-B consists of **7** very short answer questions carrying **2** marks each.
4. Section-C consists of **5** short answer questions carrying **3** marks each.
5. Section-D consists of **2** case-based questions carrying **4** marks each.
6. Section-E consists of **3** long answer questions carrying **5** marks each.

### SECTION - A

1. Calculate molality of 20% (w/v)  $\text{CaCO}_3$  solution if density is  $1.12 \text{ g/cm}^3$  [1]
  - (1) 1.12 molal
  - (2) 2.17 molal
  - (3) 1.92 molal
  - (4) 3.5 molal
2. Which of the C–X bond will have highest bond dissociation energy among the following? [1]

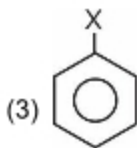
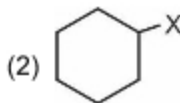
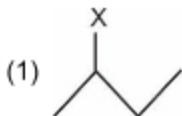

Corporate Office : Aakash Tower, 8, Pusa Road, New Delhi-110005. Ph.: 011-47623456

(29)

## Chemistry (Class XII)

## Model Test Paper-1

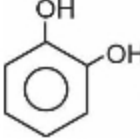
3.  is commonly known as [1]

- (1) Catechol (2) Resorcinol  
(3) o-Cresol (4) Quinol

4. Which of the following alkyl halides will be most reactive towards  $S_N1$  reaction? [1]

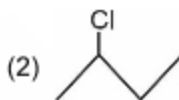

5.  $C_2H_5CN \xrightarrow{H^+, H_2O} P$  [1]

In above reaction, compound P will be

- (1)  $C_2H_5-COOH$  (2)  $CH_3-COOH$   
(3)  $C_2H_5-CHO$  (4)  $CH_3-CHO$

6. Calculate vapour pressure of solution after mixing 23 g ethyl alcohol and 36 g water. Given :  $p_{H_2O}^{\circ} = 300$  mmHg and  $p_{C_2H_5OH}^{\circ} = 400$  mmHg [1]

- (1) 380 mmHg (2) 320 mmHg  
(3) 360 mmHg (4) 350 mmHg

7. Which alcohol will give fastest white turbidity with  $HCl + ZnCl_2$ ? [1]

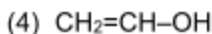
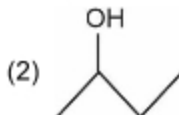

@AAKASH\_TEST\_PAPERS\_2024

Corporate Office : Aakash Tower, 8, Pusa Road, New Delhi-110005. Ph.: 011-47623456

(30)

## Model Test Paper-1

## Chemistry (Class XII)

8. How many of the following compounds are secondary alkyl halide? [1]

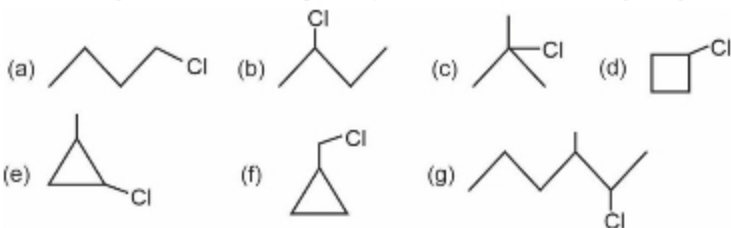

(1) 2

(2) 4

(3) 3

(4) 5

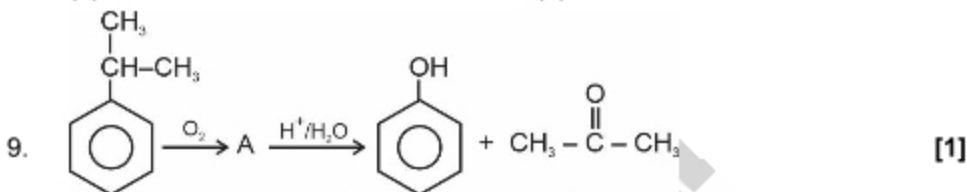

Identify compound A in above reaction

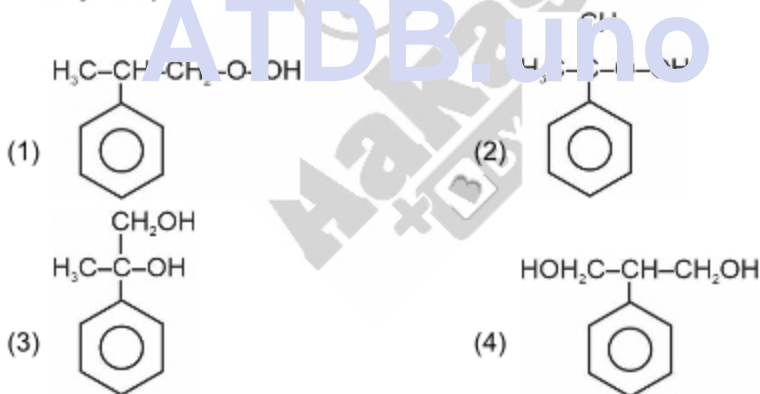

10. Which of the following is D-glucose? [1]

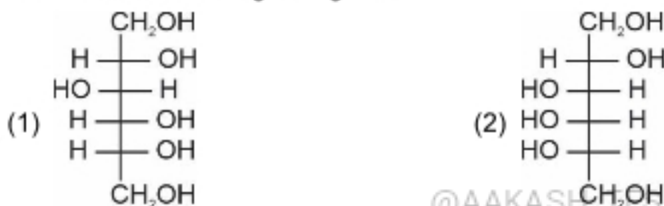

@AAKASH\_TEST\_PAPERS\_2024

Corporate Office : Aakash Tower, 8, Pusa Road, New Delhi-110005. Ph.: 011-47623456

(31)

## Chemistry (Class XII)

## Model Test Paper-1

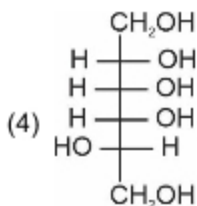
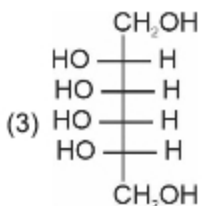

11. Which of the following is not an essential amino acid? [1]
- (1) Valine (2) Leucine  
(3) Arginine (4) Alanine
12. The order of reactivity of phenyl magnesium bromide with the following compound is [1]

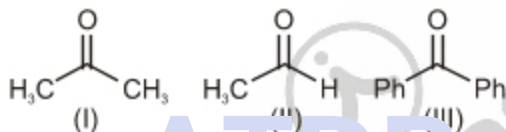

- (1) II > III > I (2) I > III > I  
(3) II > I > III (4) I > II > III
13. The resistance of conducting cell having cell constant  $0.219 \text{ cm}^{-1}$  is 1500 ohm. If the conducting cell contains 0.001 M NaCl solution then the molar conductance of the solution is (in  $\text{S cm}^2 \text{ mol}^{-1}$ ) [1]
- (1) 146 (2) 1.46  
(3) 292 (4) 2.92
14. The correct IUPAC name of  $[\text{Co}(\text{H}_2\text{NCH}_2\text{CH}_2\text{NH}_2)_3](\text{SO}_4)_3$  is [1]
- (1) Tris(ethane-1,2-diamine)cobalt(III) sulphate  
(2) Tris(ethane-1,2-diammine)cobalt(III) sulphate  
(3) Triethane-1,2-diaminecobalt(III) sulphate  
(4) Triethane-1,2-diamminecobalt(III) sulphate

@AAKASH\_TEST\_PAPERS\_2024

Corporate Office : Aakash Tower, 8, Pusa Road, New Delhi-110005. Ph.: 011-47623456

(32)

## Model Test Paper-1

## Chemistry (Class XII)

15. **Assertion :** 4-Nitrobenzoic acid is more acidic than 4-methylbenzoic acid. [1]  
**Reason :** Electron-withdrawing group increases the acidic character.
- (1) Both assertion and reason are correct statements, and reason is the correct explanation of the assertion.
  - (2) Both assertion and reason are correct statements, but reason is not the correct explanation of the assertion.
  - (3) Assertion is correct, but reason is wrong statement.
  - (4) Assertion is wrong, but reason is correct statement
16. **Assertion :** Sucrose is a non-reducing sugar. [1]  
**Reason :** In sucrose the reducing groups of glucose and fructose are involved in glycosidic bond formation.
- (1) Both assertion and reason are correct statements, and reason is the correct explanation of the assertion.
  - (2) Both assertion and reason are correct statements, but reason is not the correct explanation of the assertion.
  - (3) Assertion is correct, but reason is wrong statement.
  - (4) Assertion is wrong, but reason is correct statement
17. **Assertion :**  $\text{CH}_3 - \text{C}_2\text{Br}$  is more reactive towards  $\text{S}_\text{N}2$  than  $\text{SN}1$ . [1]  
**Reason :** Primary alkyl halides are most hindered.
- (1) Both assertion and reason are correct statements, and reason is the correct explanation of the assertion.
  - (2) Both assertion and reason are correct statements, but reason is not the correct explanation of the assertion.
  - (3) Assertion is correct, but reason is wrong statement.
  - (4) Assertion is wrong, but reason is correct statement
18. **Assertion :**  $[\text{Fe}(\text{CN})_6]^{4-}$  is strongly paramagnetic. [1]  
**Reason :** The oxidation state of Fe in  $[\text{Fe}(\text{CN})_6]^{4-}$  is +2.
- (1) Both assertion and reason are correct statements, and reason is the correct explanation of the assertion.
  - (2) Both assertion and reason are correct statements, but reason is not the correct explanation of the assertion.
  - (3) Assertion is correct, but reason is wrong statement.
  - (4) Assertion is wrong, but reason is correct statement

## Chemistry (Class XII)

## Model Test Paper-1

## SECTION - B

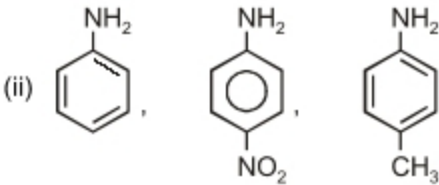
19. How many electrons flow through a metallic wire if a current of 0.5 A is passed for 2 hours? (Given : 1 F = 96, 500 C mol<sup>-1</sup>) [2]
20. Arrange the following in increasing order of their basic strength. [2]
- (i) C<sub>6</sub>H<sub>5</sub> - NH<sub>2</sub>, C<sub>6</sub>H<sub>5</sub> - CH<sub>2</sub> - NH<sub>2</sub>, C<sub>6</sub>H<sub>5</sub> - NH - CH<sub>3</sub>
- (ii) 
21. When a coordination compound CoCl<sub>3</sub>·6NH<sub>3</sub> is mixed with excess of AgNO<sub>3</sub>, 3 moles of AgCl are precipitated per mole of the compound. Write
- (i) Structural formula of the complex [1]
- (ii) IUPAC name of the complex [1]
22. For a reaction,  $\text{H}_2 + \text{Cl}_2 \rightarrow 2\text{HCl}$
- Rate = k
- (i) Write the order of this reaction. [1]
- (ii) Write the unit of k. [1]
23. Using IUPAC norms write the formulae for the following coordination compounds: [2]
- (i) Dichloridobis(ethane-1, 2-diamine)cobalt(III)chloride
- (ii) Potassium tetrachloridonickelate(II)

OR

Draw crystal field splitting energy diagram for octahedral complex.

24. Given that, the standard electrode potential (E°) of metals are [2]
- Li<sup>+</sup>/Li = -3.05 V
- Al<sup>3+</sup>/Al = -1.66 V
- Fe<sup>2+</sup>/Fe = -0.44 V
- Sn<sup>2+</sup>/Sn = -0.14 V

Arrange these metals in an increasing order of their reducing power.

Corporate Office : Aakash Tower, 8, Pusa Road, New Delhi-110005. Ph.: 011-47623456

(34)

## Model Test Paper-1

## Chemistry (Class XII)

OR

A galvanic cell is represented as



- (a) Which one of its electrodes is positively charged?  
 (b) Write the reaction taking place at each of its electrode.

25. Account for the following : [2]

- (a) Electrophilic substitution in case of aromatic amines takes place more readily than benzene.  
 (b) Ethylamine is soluble in water whereas aniline is not soluble in water.

OR

- (a) Aniline readily reacts with bromine to give 2, 4, 6-tribromoaniline.  
 (b) Aniline does not undergo Friedel-Crafts reaction.

## SECTION - C

26. For the first-order thermal decomposition reaction, the following data were obtained. [3]

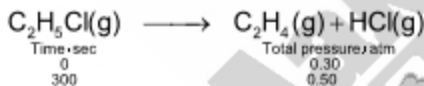

Calculate the rate constant.

(Given:  $\log 2 = 0.301$ ,  $\log 3 = 0.4771$ ,  $\log 4 = 0.6021$ )

OR

Vapour pressure of water at 20°C is 17.5 mm Hg. Calculate the vapour pressure of water at 20°C when 15 g of glucose (Molar mass = 180 g mol<sup>-1</sup>) is dissolved in 150 g of water. [3]

27. Account for the following

- (a) Aniline cannot be prepared by Gabriel phthalimide synthesis.  
 (b) Benzaldehyde does not give Fehling reagent test.  
 (c)  $\text{Mn}^{3+}$  is oxidising in nature. [1 × 3 = 3]

## Chemistry (Class XII)

## Model Test Paper-1

OR

Convert the following.

- (a) Ethanamine to ethanol  
(b) 1-Propanol to propanal  
(c) Toluene to Benzaldehyde

[1 × 3 = 3]

28. Calculate  $E_{\text{cell}}^{\circ}$  and  $\Delta G^{\circ}$  for following reaction at 25°C.

[3]

Given :  $K_C = 10^{10}$ , 1 F = 96500 C/mol

29. A compound X with molar mass 106 g/mol, reduces Tollen's reagent but does not react with Fehling reagent. On reaction with 50% KOH followed by hydrolysis gives compounds 'Y' and 'Z'. Compound Y on reaction with  $\text{LiAlH}_4$  gives compound 'Z'. Write down structure of compound X, Y and Z and also reactions mentioned.

[3]

30. Answer the following

[1 × 3 = 3]

(a) Arrange following complexes in increasing order of their metal carbon bond length.



(b) Arrange following complexes in increasing order of their absorbed wavelength of light.



(c) Calculate the 'spin only' magnetic moment of  $\text{M}^{2+}(\text{aq})$  ion ( $Z = 26$ )

OR

Answer the following.

- (a) Why are Zn, Cd and Hg not called typical transition elements?  
(b) Mn shows minimum heat of atomisation among all 3d series transition elements why?  
(c) Why  $[\text{Ni}(\text{dmg})_2]$  provides more stability than  $[\text{Ni}(\text{en})_2]^{2+}$  despite having same number of didentate ligand?

@AAKASH\_TEST\_PAPERS\_2024

Corporate Office : Aakash Tower, 8, Pusa Road, New Delhi-110005. Ph.: 011-47623456

(36)

## SECTION - D

## (Case-based Question)

31. Read the passage given below and answer the questions that follow.

Age of fossil is estimated by carbon dating also known as Radiocarbon dating, it is a method to determine the age of an object containing organic material by using radioactivity of  $^{14}\text{C}$  (radioactive isotope of carbon).

It is based on the fact that radiocarbon ( $^{14}\text{C}$ ) is constantly being created in the Earth's atmosphere by the interaction of cosmic rays with atmospheric nitrogen. The resulting  $^{14}\text{C}$  combines with atmospheric oxygen to form radioactive carbon dioxide, which is incorporated into plants by photosynthesis; animals then acquire  $^{14}\text{C}$  by eating the plants. When the animal or plant dies, it stops exchanging carbon with its environment, and thereafter the amount of  $^{14}\text{C}$  it contains begins to decrease as the  $^{14}\text{C}$  undergoes radioactive decay. Measuring the amount of  $^{14}\text{C}$  in a sample from a dead plant or animal, such as a piece of wood or a fragment of bone, provides information that can be used to calculate when the animal or plant died. The older a sample, the less  $^{14}\text{C}$  there is to be detected, and because the half-life of  $^{14}\text{C}$  (the period of time after which half of a given sample will have decayed) is about 5730 years, the oldest dates that can be reliably measured by this process date to approximately 50,000 years ago.

Radioactive decay is based on first-order kinetics in which rate of decay will be directly proportional to the concentration of material present.

And for first-order kinetics

$$t = \frac{2.303}{k} \log \left( \frac{a_0}{a_0 - x} \right)$$

Where  $t \rightarrow$  Time taken

$k \rightarrow$  Rate constant

$a_0 \rightarrow$  Initial concentrations of  $^{14}\text{C}$  in sample

$x \rightarrow$  Amount of  $^{14}\text{C}$  consumed after time 't'

- (a) Calculate rate constant for  $^{14}\text{C}$  decay in  $\text{year}^{-1}$  [1]
- (b) If a sample contains  $1/16^{\text{th}}$  of initial concentration of  $^{14}\text{C}$  then calculate age of sample. [1]
- (c) Plot a graph between concentration of  $^{14}\text{C}$  at time (a) v/s time (t). [2]

## Chemistry (Class XII)

## Model Test Paper-1

OR

Slope of graph between  $\log(a_t)$  v/s time(t) will be

[2]

## Case Study Question

32 Aldehydes, Ketones and Carboxylic acids can be prepared from different methods using hydrocarbons, nitriles and esters, acrylic chlorides etc. The aldehydes and ketones undergo a number of reactions due to the acidic nature of  $\alpha$ -hydrogen. The acidity of  $\alpha$ -hydrogen atoms of carbonyl compounds is due to the strong electron withdrawing effect of the carbonyl group and resonance stabilisation of the conjugate base.

Aldehydes, Ketones and Carboxylic acids can be prepared from different methods. One of the important method is using Grignard reagent. Grignard reagents react with carbon dioxide (dry ice) to form salts of carboxylic acids which in turn give corresponding carboxylic acids after acidification with mineral acid.

Acid chlorides when hydrolysed with water give carboxylic acids or more readily hydrolysed with aqueous base to give carboxylate ions which on acidification provide corresponding carboxylic acids. Anhydrides on the other hand are hydrolysed to corresponding acid(s) with water. Acidic hydrolysis of esters give directly carboxylic acids while basic hydrolysis gives carboxylates, which on acidification give corresponding carboxylic acids.

(a) Write the structure of compounds A, B and C in each of the following reaction: [3]

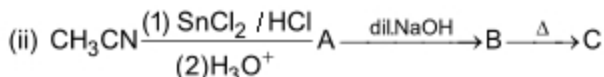
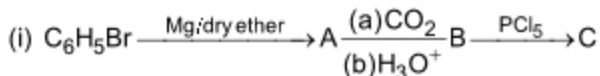

(b) Write the product in the following reaction [1]

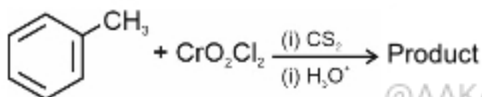

@AAKASH\_TEST\_PAPERS\_2024

Corporate Office : Aakash Tower, 8, Pusa Road, New Delhi-110005. Ph.: 011-47623456

(38)

## Model Test Paper-1

## Chemistry (Class XII)

OR

- (a) Write the reaction involved in the Stephen reduction. [1]

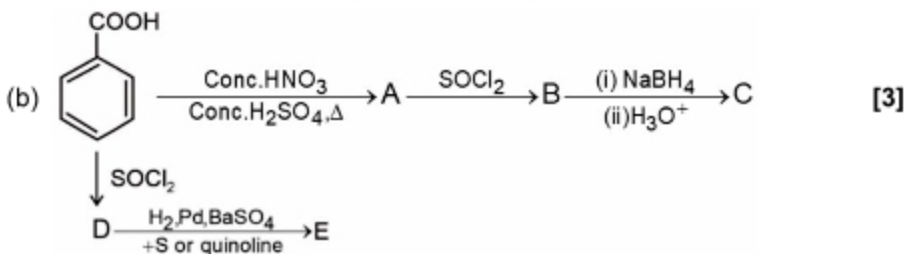

## SECTION - E

33. (a) Describe the mechanism of esterification reaction of carboxylic acid with alcohol in acidic medium. [2]  
 (b) Complete the reaction [3]

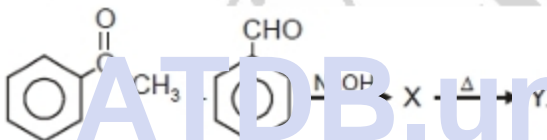

OR

- Identify A, B, C, D, E and F. [5]

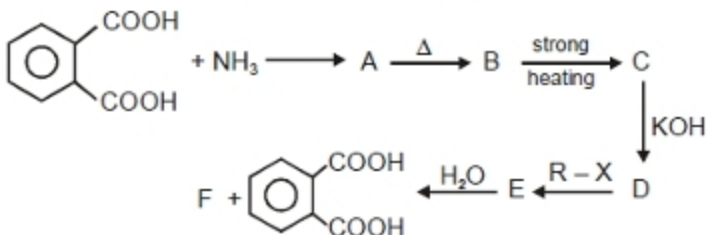

34. (i) Account for the following equations: [3]  
 (a) Mn shows the highest oxidation state of +7 with oxygen but with fluorine it shows the highest oxidation state of +4  
 (b) Zr and Hf have similar properties  
 (c) Transition metals act as catalysts

## Chemistry (Class XII)

## Model Test Paper-1

(ii) Complete the following equations: [2]



OR

The elements of 3d transition series are given as:

Sc, Ti, V, Cr, Mn, Fe, Co, Ni, Cu, Zn

Answer the following:

(i) Zn is not regarded as transition element. Give reason. [1]

(ii) Which element has the highest mp? [1]

(iii) Which element shows +1 oxidation state? [1]

(iv) Which element is a strong oxidizing agent in +3 oxidation state and why? [2]

35. (a) Calculate  $E_{\text{cell}}$  for the following reaction at 298 K [3]



Given :  $E_{\text{cell}} = 0.261\text{ V}$

(b) Using the  $E^\circ$  values of A and B, predict which one is better for coating the surface of iron [ $E^\circ(\text{Fe}^{2+}/\text{Fe}) = -0.44\text{ V}$ ] to prevent corrosion and why. [2]

Given :  $E^\circ(\text{A}^{2+}/\text{A}) = -2.37\text{ V}$  ;  $E^\circ(\text{B}^{2+}/\text{B}) = -0.14\text{ V}$

□ □ □

@AAKASH\_TEST\_PAPERS\_2024

Corporate Office : Aakash Tower, 8, Pusa Road, New Delhi-110005. Ph.: 011-47623456

(40)

## Model Test Paper-2

## Chemistry (Class XII)

Time: 3 Hours

# Model Test Paper-2

## for

### School/Board Exams

M.M.: 70

## CHEMISTRY

**Topics:** Complete Syllabus of Class XII

### General Instructions:

1. There are **35** questions in this question paper with internal choice.
2. Section-A consists of **18** multiple-choice questions carrying **1** mark each.
3. Section-B consists of **7** very short answer questions carrying **2** marks each.
4. Section-C consists of **5** short answer questions carrying **3** marks each.
5. Section-D consists of **2** case-based questions carrying **4** marks each.
6. Section-E consists of **3** long answer questions carrying **5** marks each.

### SECTION - A

1. Molecule having minimum  $pK_a$  is

[1]

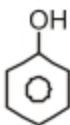
(1)  $H - COOH$ (2)  $\begin{array}{c} COOH \\ | \\ COOH \end{array}$ (3)  $CH_3 - COOH$ (4) 

2.

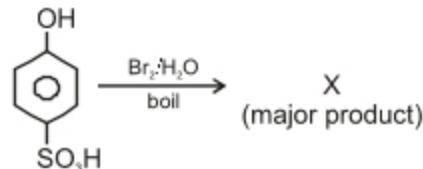

X is identified as

@AAKASH\_TEST\_PAPERS\_20 [1]

Corporate Office : Aakash Tower, 8, Pusa Road, New Delhi-110005. Ph.: 011-47623456

(41)

## Chemistry (Class XII)

## Model Test Paper-2

- (1) 2,4,6-tribromophenol  
 (2) 2-bromophenol  
 (3) 3-bromophenol  
 (4) 2-bromo-4-hydroxy benzene sulphonic acid
3. If density of methanol is  $0.8 \text{ kg L}^{-1}$  then calculate how much volume of this solution will be needed to prepare 2.5 L, 0.25 M methanol solution. [1]
- (1) 25 L (2) 25 ml  
 (3) 50 L (4) 5 ml
4. Which of the following is not an Aryl halide? [1]

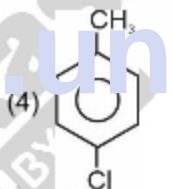
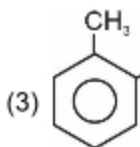
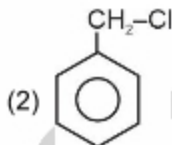
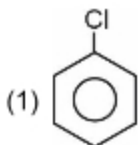

5. Which of the following alkyl halide will give racemic mixture as product if undergoes  $S_N1$  reaction? [1]
- (1)  $\text{CH}_3\text{-CH}_2\text{Cl}$  (2)  $\text{CH}_3\text{-CHDCI}$   
 (3)  $\text{CH}_2\text{D-CH}_2\text{Cl}$  (4)  $\text{CD}_3\text{-CH}_2\text{-Cl}$
6. What will be IUPAC name of ethyl isopropyl ether? [1]
- (1) 1-methyl-2-ethoxy ethane (2) 1-ethoxy propane  
 (3) 2-ethoxy propane (4) 1-isopropoxy ethane
7. Six-membered cyclic structure of glucose is called \_\_\_\_\_. [1]
- (1) Furanose (2) Pyranose  
 (3) Mannose (4) Ketohexose

@Aakash\_TST\_PAPERS\_2024

## Model Test Paper-2

## Chemistry (Class XII)

8. Which among the following is a water-soluble vitamin? [1]  
 (1) Vitamin A (2) Vitamin C  
 (3) Vitamin D (4) Vitamin K

9. Organic compound 'A' is [1]

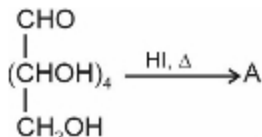

- (1) n-Hexane (2) Gluconic acid  
 (3) Saccharic acid (4) Hexene
10. Which among the following is correct increasing order of oxidising power? [1]  
 (1)  $\text{MnO}_4^- < \text{Cr}_2\text{O}_7^{2-} < \text{VO}_2^+$  (2)  $\text{Cr}_2\text{O}_7^{2-} < \text{MnO}_4^- < \text{VO}_2^+$   
 (3)  $\text{VO}_2^+ < \text{Cr}_2\text{O}_7^{2-} < \text{MnO}_4^-$  (4)  $\text{MnO}_4^- < \text{VO}_2^+ < \text{Cr}_2\text{O}_7^{2-}$
11. Which of the following compounds is most reactive towards  $\text{S}_{\text{N}}2$  reaction? [1]



- (3)  $\text{CH}_3-\text{CH}_2-\text{Cl}$  (4)  $\text{CH}_3-\text{Cl}$
12. Which of the following is an example of solid solution? [1]  
 (1) Soft drinks (2) Salt in water  
 (3)  $\text{H}_2$  in Pd (4) Camphor in  $\text{N}_2$

13. Consider the given reactions [1]

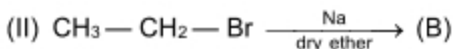
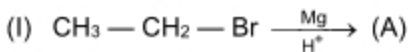

Which of the following statements is correct?

- (1) Molar mass of A is less than that of B  
 (2) Molar mass of B is less than that of A  
 (3) Molar masses of A and B are equal  
 (4) A and B are isomers

@AAKASH\_TEST\_PAPERS\_2024

Corporate Office : Aakash Tower, 8, Pusa Road, New Delhi-110005. Ph.: 011-47623456

(43)

## Chemistry (Class XII)

## Model Test Paper-2

14. Which of the following is a vinylic halide? [1]

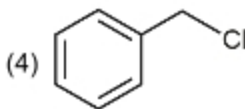
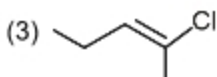
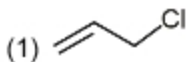

15. Given below are two statements labelled as Assertion (A) and Reason (R). [1]

**Assertion (A):** Phenol is more reactive than benzene towards electrophilic substitution reaction.

**Reason (R):** In case of phenol, the intermediate carbocation is more resonance stabilised.

Select the most appropriate answer from the options given below:

- (1) Both A and R are true and R is the correct explanation of A  
(2) Both A and R are true but R is not the correct explanation of A  
(3) A is true but R is false  
(4) A is false but R is true
16. Given below are two statements labelled as Assertion (A) and Reason (R). [1]

**Assertion (A):** When a solution is separated from the pure solvent by a semi-permeable membrane (SPM), the solvent molecules pass through SPM from pure solvent side to the solution side.

**Reason (R):** Net diffusion of solvent occurs from a region of high concentration solution to a region of low concentration solution.

Select the most appropriate answer from the options given below:

- (1) Both A and R are true and R is the correct explanation of A  
(2) Both A and R are true but R is not the correct explanation of A  
(3) A is true but R is false  
(4) A is false but R is true

@AAKASH\_TEST\_PAPERS\_2024

Corporate Office : Aakash Tower, 8, Pusa Road, New Delhi-110005. Ph.: 011-47623456

(44)

## Model Test Paper-2

## Chemistry (Class XII)

17. **Assertion (A):** Molar conductivity of weak electrolyte increases with dilution. [1]

**Reason (R):** On dilution, interionic distance as well as degree of ionization increases for weak electrolyte.

- (1) Both A and R are true and R is the correct explanation of A
- (2) Both A and R are true but R is not the correct explanation of A
- (3) A is true but R is false
- (4) A is false but R is true

18. **Assertion (A):**   $\text{N}_2^+\text{Cl}^-$  is more stable than  $\text{C}_2\text{H}_5\text{N}_2^+\text{Cl}^-$ . [1]

**Reason (R):** C-N bond in   $\text{N}_2^+\text{Cl}^-$  has double bond character.

- (1) Both A and R are true and R is the correct explanation of A
- (2) Both A and R are true but R is not the correct explanation of A
- (3) A is true but R is false
- (4) A is false but R is true

## SECTION - B

19. Differentiate between molecularity and order of a reaction. [2]
20. Give reasons. [2]
- (a) Phenol has higher boiling point than toluene.
  - (b) Phenol can be easily nitrated in comparison to benzene.

OR

Give reasons.

- (a) *o*-Nitrophenol is more acidic than *o*-methoxy phenol.
  - (b) Ethers possess a dipole moment even if the alkyl groups in the molecule are identical. [2]
21. A complex of the type  $[\text{M}(\text{AA})_2\text{X}_2]^{n+}$  is known to be optically active. What does this indicate about the structure of the complex? Give one example of such complex. [2]

@AAKASH\_TEST\_PAPERS\_2024

Corporate Office : Aakash Tower, 8, Pusa Road, New Delhi-110005. Ph.: 011-47623456  
(45)

## Chemistry (Class XII)

## Model Test Paper-2

22. Name the reagent used in the following reactions: [2]

- (a) Conversion of phenol to 4-bromophenol.  
 (b) Oxidation of primary alcohol to aldehyde.

OR

Complete the following reaction.

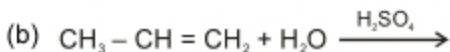
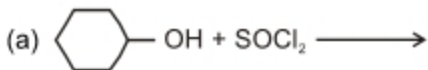

23. Arrange the following in the increasing order of their property indicated

[Any 2]

- (a) Benzoic acid, 4-nitrobenzoic acid, 4-methoxy benzoic acid (pK<sub>a</sub> values)  
 (b) n-C<sub>4</sub>H<sub>9</sub>OH, n-C<sub>4</sub>H<sub>9</sub>NH<sub>2</sub>, (C<sub>2</sub>H<sub>5</sub>)<sub>2</sub>NH, C<sub>2</sub>H<sub>5</sub>CH(CH<sub>3</sub>)<sub>2</sub> (boiling point)  
 (c) CH<sub>3</sub>NH<sub>2</sub>, NH<sub>3</sub>, (CH<sub>3</sub>)<sub>3</sub>N, (CH<sub>3</sub>)<sub>2</sub>NH (basic nature in aqueous solution)

[1 × 2 = 2]

24. Explain why  $\Lambda_m^\infty$  of CH<sub>3</sub>COOH increases slowly for KCl solution whereas  $\Lambda_m^\infty$  increases steadily for CH<sub>3</sub>COOH solution. Graphically show the behaviour on dilution for both electrolytes. [2]

25. Give reason to support the answer.

- (a) Benzoic acid does not undergo Friedel-Crafts reaction.  
 (b)  $\alpha$ -Hydrogen atoms of acetaldehyde is acidic in nature.

[1 × 2 = 2]

## SECTION - C

26. How will you bring about the following conversions? [3]

- (a) But-1-ene to but-2-ene  
 (b) 1-chlorobutane to n-octane  
 (c) Toluene to benzyl alcohol

OR

Explain the following observations

- (a) The dipole moment of chlorobenzene is lower than that of cyclohexylchloride.  
 (b) Alkyl halides, though polar, are immiscible with water.  
 (c) Grignard reagents should be prepared under anhydrous conditions.

## Model Test Paper-2

## Chemistry (Class XII)

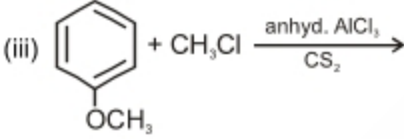
27. Why  $[\text{Fe}(\text{CN})_6]^{3-}$  is weakly paramagnetic while  $[\text{Fe}(\text{CN})_6]^{4-}$  is diamagnetic? Explain using Valence Bond Theory. [3]
28. Write the structure of the major product in each of the following reactions.
- (i)  $\text{CH}_3 - \text{CH} = \underset{\text{CH}_3}{\text{C}} - \text{CH}_3 + \text{HBr} \longrightarrow$  [1]
- (ii)  $\text{CH}_3 - \text{CH}_2 - \text{CH}_2 - \underset{\text{Br}}{\text{CH}} - \text{CH}_3 + \text{KOH} \xrightarrow{\text{ethanol/heat}}$  [1]
- (iii)  [1]
29. Write down the method to distinguish between primary, secondary and tertiary alcohols. [3]
- OR**
- How will you convert
- (a) Benzene to benzophenone?
- (b) Benzyl chloride to benzyl alcohol?
- (c) Bromobenzene to benzoic acid?
30. There are two volatile components A and B having vapour pressures 200 mm Hg and 300 mm Hg respectively. If an ideal mixture is formed by mixing of both components, calculate the vapour pressure of solution if mole fraction of component B is 0.6 in vapour phase. [3]

## SECTION - D

31. Read the passage given below and answer the questions that follow:  
Zero-order reaction means that the rate of the reaction is proportional to zero power of the concentration of reactants.  
Consider the reaction,  $\text{R} \rightarrow \text{P}$   
$$\text{rate} = \frac{-d[\text{R}]}{dt} = k[\text{R}]^0 = k$$
  
On integrating we get,  
$$k = \frac{[\text{R}]_0 - [\text{R}]}{t}$$

@AAKASH\_TEST\_PAPERS\_2024

Corporate Office : Aakash Tower, 8, Pusa Road, New Delhi-110005. Ph.: 011-47623456

(47)

## Chemistry (Class XII)

## Model Test Paper-2

Where  $[R]_0$  is the initial concentration of reactant whereas  $[R]$  is the concentration of reactant at time  $t$ .

Zero-order reactions are relatively uncommon but they occur under special conditions. Some enzyme-catalysed reactions and reactions which occur on metal surface are few examples of zero-order reactions.

- (a) Draw a graph between concentration of reactant R vs time for zero-order reaction. **[1]**
- (b) What is the unit of rate constant for zero-order reaction? **[1]**
- (c) The rate of a zero-order reaction is  $10^{-2} \text{ mol L}^{-1} \text{ s}^{-1}$ , starting with 10 M concentration of reactant, calculate time in which concentration of reactant decreases to 4 M. **[2]**

32. Amines are prepared from various methods using reducing nitriles, amides *etc.* Difference in electronegativity between nitrogen and hydrogen atoms and the presence of unshared pair of electrons over the nitrogen atom makes amines reactive.

The diazonium salts have the general formula  $RN_2^+ X^-$  where R stands for any aryl group and  $X^-$  may be  $Cl^-$ ,  $Br^-$ ,  $H_2O_4^-$ ,  $BF_4^-$  *etc.* They are named by suffixing diazonium the name of the parent hydrocarbon from which they are formed, followed by the name of anion such as chloride, hydrogensulphate, *etc.* The  $N_2^+$  group is called diazonium group. Due to its instability, the diazonium salt is not generally stored and is used immediately after its preparation.

- (a) Write the structures of A, B and C in the following reactions: **[3]**

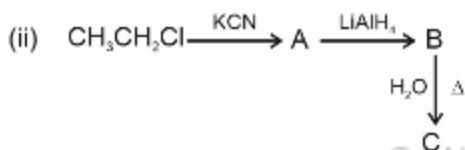
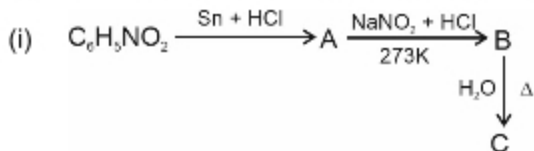

@AKASH\_TEST\_PAPERS\_2024

Corporate Office : Aakash Tower, 8, Pusa Road, New Delhi-110005. Ph.: 011-47623456

(48)

## Model Test Paper-2

## Chemistry (Class XII)

- (b) Complete the following reaction: [1]

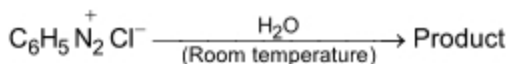

OR

- (a) Give reason why HCl does not give anti-Markownikoff's addition product with propene. [1]
- (b) An aromatic compound 'A' on treatment with aqueous ammonia and heating forms compound 'B' which on heating with Br<sub>2</sub> and KOH forms a compound 'C' of molecular formula C<sub>6</sub>H<sub>7</sub>N. Write the structures of compounds A, B, and C. [3]

## SECTION - E

33. (a) A solution of CuSO<sub>4</sub> is electrolysed for 10 minutes with a current of 1.5 amperes. What is mass of copper deposited at the cathode? (Cu = 63.5 g/mol) [2]
- (b) The conductivity of 0.0108 mol L<sup>-1</sup> acetic acid is 4.9 × 10<sup>-5</sup> S cm<sup>-1</sup>. Calculate its dissociation constant if λ<sub>m</sub><sup>0</sup> for acetic acid is 390.5 S cm<sup>2</sup> mol<sup>-1</sup>. [3]

OR

- (a) The standard electrode potential for Daniel cell is 1.1 V. Calculate the standard Gibbs energy for the reaction. [2]
- (b) Calculate the emf of the cell in which the following reaction takes place.  

$$\text{Ni(s)} + 2\text{Ag}^+(0.002 \text{ M}) \longrightarrow \text{Ni}^{2+}(0.160 \text{ M}) + 2\text{Ag(s)}$$
 Given that E<sub>cell</sub><sup>0</sup> = 1.05 V [3]
34. (a) An organic compound 'A' (C<sub>5</sub>H<sub>10</sub>O) is reduced to n-Pentane on reduction with Zn-Hg/HCl. 'A' forms an oxime with NH<sub>2</sub>OH and gives a positive iodoform test and negative Tollen's Test. Identify the compound A and deduce its structure. [2]

@AAKASH\_TEST\_PAPERS\_2024

## Chemistry (Class XII)

## Model Test Paper-2

- (b) Write the chemical equations for the following conversions. [3]
- Ethylbenzene to benzene.
  - Acetaldehyde to butane-1, 3, diol.
  - Acetone to propane.

OR

- (a) An organic compound 'A' with molecular formula  $C_8H_8O$  gives positive DNP and iodoform test. It does not reduce Tollen's or Fehling's reagent and does not decolourize bromine water. On oxidation with chromic acid ( $H_2CrO_4$ ), it gives carboxylic acid (B) with molecular formula  $C_7H_6O_2$ . Deduce the structures of A and B. [3]
- (b) Complete the following reactions by identifying A, B and C. [2]

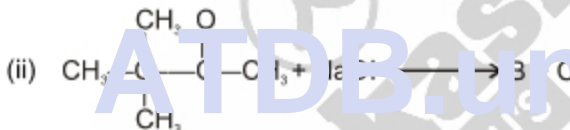
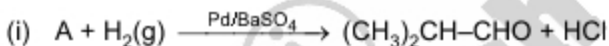

35. (a) Can Lanthanum ion exist in +4 oxidation state? Justify. [1½]
- (b) Why is Europium (II) more stable than Cerium (II)? [1½]
- (c) Why is Scandium (Z = 21) a transition element but Zinc (Z = 30) is not? [2]

OR

- (a) Give the cause of lanthanoid contraction. [2]
- (b) Differentiate between actinoids and lanthanoids (6 points). [3]

□ □ □

@AAKASH\_TEST\_PAPERS\_2024

Corporate Office : Aakash Tower, 8, Pusa Road, New Delhi-110005. Ph.: 011-47623456  
(50)

Time: 3 Hours

# Model Test Paper-3

for  
School/Board Exams

M.M.: 70

## CHEMISTRY

*Topics:* Complete Syllabus of Class XII**General Instructions:**

1. There are **35** questions in this question paper with internal choice.
2. Section-A consists of **18** multiple-choice questions carrying **1** mark each.
3. Section-B consists of **7** very short answer questions carrying **2** marks each.
4. Section-C consists of **5** short answer questions carrying **3** marks each.
5. Section-D consists of **2** case-based questions carrying **4** marks each.
6. Section-E consists of **3** long answer questions carrying **5** marks each.

### SECTION - A

1. Which of the following shows negative deviation from Raoult's law? [1]  
(1) Heptane and hexane  
(2) Chloroform and acetone  
(3) Acetone and ethanol  
(4) Iodobenzene and chlorobenzene
2. If an aqueous solution has molality 11.11 m, then the mole fraction of solute in the solution is [1]  
(1) 0.16 (2) 0.83  
(3) 0.42 (4) 0.60
3. Wurtz-Fittig reaction is best possible in which of the following solvents? [1]  
(1) Acetone (2) Water  
(3) Dry ether (4) Moist ether

@AAKASH\_TEST\_PAPERS\_2024

Corporate Office : Aakash Tower, 8, Pusa Road, New Delhi-110005. Ph.: 011-47623456  
(51)

## Chemistry (Class XII)

## Model Test Paper-3

4. What will be the correct order of dehydration of the following alcohols? [1]

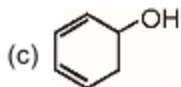
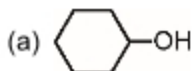

(1) (a) > (b) > (c)

(2) (c) > (b) > (a)

(3) (b) > (c) > (a)

(4) (a) > (c) > (b)

5. Reimer-Tiemann reaction is used to prepare [1]

(1) Salicylic acid

(2) Hydroxyquinone

(3) Picric acid

(4) Salicylaldehyde

6. Ammonia is made to react with aqueous copper and a deep blue coloured complex is formed. The formula of the complex formed is [1]

(1)  $[\text{Cu}(\text{NH}_3)_6]^{2+}$

(2)  $[\text{Cu}(\text{H}_2\text{O})_4(\text{NH}_3)_4]^{2+}$

(3)  $[\text{Cu}(\text{NH}_3)_4]^{2+}$

(4)  $[\text{Cu}(\text{NH}_3)_2(\text{H}_2\text{O})_2]^{2+}$

7. An aqueous solution freezes at  $-0.186^\circ\text{C}$  ( $K_f = 1.86 \text{ K kg mol}^{-1}$ ), ( $K_b = 0.512 \text{ K kg mol}^{-1}$ ). The elevation in boiling point of the solution is [1]

(1)  $0.186^\circ\text{C}$

(2)  $0.512^\circ\text{C}$

(3)  $1.86^\circ\text{C}$

(4)  $0.0512^\circ\text{C}$

8. Which of the following statements is incorrect for  $\text{S}_{\text{N}}1$  reactions? [1]

(1) It prefers polar protic solvent

(2) The rate depends upon stability of carbocation

(3) Complete inversion of configuration takes place

(4) The rate is unaffected by the concentration of nucleophile

## Model Test Paper-3

## Chemistry (Class XII)

9. The most acidic compound among the following is [1]

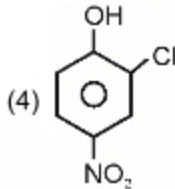
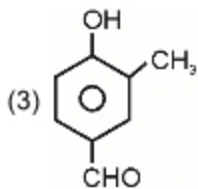
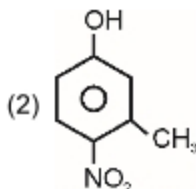
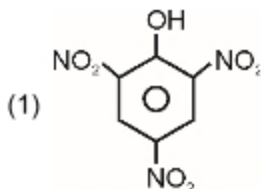

10. Consider the reaction [1]

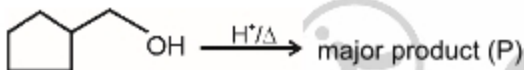

The total number of oxygen atoms in product P is

- (1) 6 (2) 8  
(3) 4 (4) 10
11. Which of the following linkages is present in nucleic acids? [1]
- (1) Peptide linkage (2) Glycosidic linkage  
(3) Phosphodiester linkage (4) Amide linkage
12. The major product formed on reaction of glucose with nitric acid is [1]
- (1) n-Hexane (2) Gluconic acid  
(3) Saccharic acid (4) Glucose pentaacetate

13. The IUPAC name of is [1]
- (1) 2-Nitro-1-cyclopentoxyethane (2) 1-Cyclopentoxy-2-nitroethane  
(3) 2-Nitro-1-ethoxycyclopentane (4) 1-Ethoxy-2-nitrocyclopentane

## Chemistry (Class XII)

## Model Test Paper-3

14. The structure of cumene is

[1]

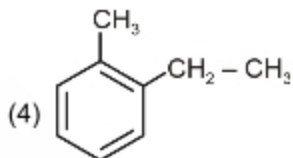
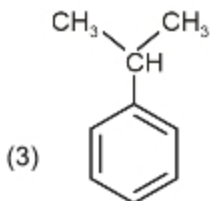
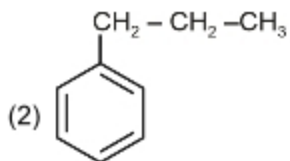
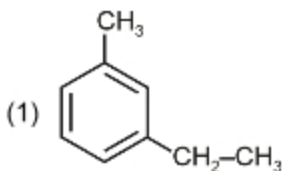

15. Given below are two statements labelled as Assertion (A) and Reason (R). [1]

**Assertion (A):** The two strands of DNA are complementary to each other.**Reason (R):** The hydrogen bond is formed between specific base pairs.

Select the most appropriate answer from the options given below:

- (1) Both A and R are true and R is the correct explanation of A  
 (2) Both A and R are true but R is not the correct explanation of A  
 (3) A is true but R is false  
 (4) A is false but R is true

16. On increasing temperature, the rate constant of a reaction

[1]

- (1) Increases (2) Decreases  
 (3) Remains same (4) Initially decreases then increases

17. **Assertion:** Glycinate ion is an unsymmetrical bidentate ligand.

[1]

**Reason :** Glycinate is conjugate base of glycine.

- (1) Both A and R are true and R is the correct explanation of A  
 (2) Both A and R are true but R is not the correct explanation of A  
 (3) A is true but R is false  
 (4) A is false but R is true

@AAKASH\_TEST\_PAPERS\_2024

Corporate Office : Aakash Tower, 8, Pusa Road, New Delhi-110005. Ph.: 011-47623456

(54)

## Model Test Paper-3

## Chemistry (Class XII)

18. **Assertion:** Aniline undergoes Friedel-Crafts alkylation reaction. [1]

**Reason :** Aniline is less basic than methyl amine.

- (1) Both A and R are true and R is the correct explanation of A
- (2) Both A and R are true but R is not the correct explanation of A
- (3) A is true but R is false
- (4) A is false but R is true

## SECTION - B

19. Arrange the following in the increasing order of their property indicated.

[(Any 2)  $1 \times 2 = 2$ ]

- (a) Formic acid, acetic acid, propanoic acid, trichloro acetic acid ( $K_a$  values).
- (b) Formaldehyde, benzaldehyde, acetone (reactivity towards  $\text{NaHSO}_3$ ).
- (c) Propylamine, N-methylethanamine, N, N-dimethylmethanamine. (Extent of H-bonding in water)

20. Give reasons to support the answer. [1  $\times$  2 = 2]

- (a) Benzaldehyde when undergoes electrophilic substitution with  $\text{HNO}_3/\text{H}_2\text{SO}_4$  at (273-283 K) gives m-nitrobenzaldehyde.
- (b) Acidic hydrolysis of ethyl benzoate gives benzoic acid as one of the products.

21. For  $\text{CH}_3\text{CHO}(\text{g}) \longrightarrow \text{CH}_4(\text{g}) + \text{CO}(\text{g})$ ; Rate =  $k[\text{CH}_3\text{CHO}]^{3/2}$ .

Determine the order of the reaction and unit of rate constant. [2]

22. Write down the IUPAC name of the complex  $[\text{Pt}(\text{en})_2\text{Cl}_2]^{2+}$ . What type of isomerism is shown by this complex? [2]

23. 1.0 g of a non-electrolyte solute dissolved in 50 g of benzene lowered the freezing point of benzene by 0.40 K. The freezing point depression constant of benzene is  $5.12 \text{ K kg mol}^{-1}$ . Find the molar mass of solute. [2]

24. Calculate pH of electrolyte solution of hydrogen electrode having oxidation potential of 0.1182 V. [2]

@AAKASH\_TEST\_PAPERS\_2021

Corporate Office : Aakash Tower, 8, Pusa Road, New Delhi-110005. Ph.: 011-47623456

(55)

## Chemistry (Class XII)

## Model Test Paper-3

25. Calculate number of Faraday required to reduce one mole of  $\text{MnO}_4^-$  ion to  $\text{Mn}^{2+}$  ion. [2]

## SECTION - C

26. Account for the following. [1 × 3 = 3]

- (a) Explain why  $\text{CH}_3 - \overset{\text{O}}{\parallel} \text{C} - \text{Cl}$  does not give iodoform with  $\text{I}_2$  and  $\text{NaOH}$ ?
- (b) Methylamine in water reacts with ferric chloride to precipitate hydrated ferric oxide.
- (c) Aniline when reacts with bromine water at room temperature gives white precipitate.

OR

Convert the following

- (a) Benzene to phenylacetic acid
- (b) Benzaldehyde to benzophenone
- (c) Propanoic acid to ethanamine
27. An alkene 'A' (molecular formula  $\text{C}_7\text{H}_{12}$ ) on reductive ozonolysis gives a mixture of two compounds 'B' and 'C'. Compound 'B' gives positive Fehling's test but does not respond iodoform test. Compound C on reaction with  $\text{Zn} - \text{HCl}$  gives cyclohexane and can give aldol condensation but does not give positive Tollen's test. Identify compounds A, B and C and write the reaction of aldol condensation product of compound 'C'. [3]
28. The rate of a reaction quadruples when the temperature changes from 293 K to 313 K. Calculate the energy of activation of the reaction assuming that it does not change with temperature.

$$[R = 8.314 \text{ JK}^{-1} \text{ mol}^{-1}, \log 4 = 0.6020] \quad [3]$$

## Model Test Paper-3

## Chemistry (Class XII)

29. Draw the structures of major monohaloproducts formed in each of the following reactions:

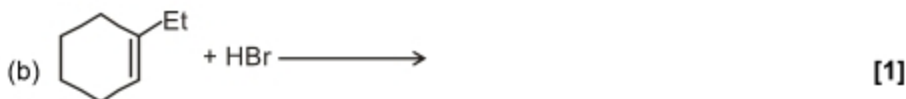
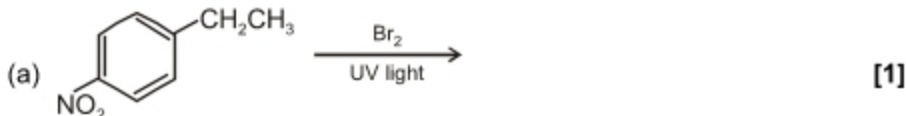

OR

- (a) Write the mechanism of acid dehydration of ethanol to yield ethene. [2]
- (b) Give reason for the higher boiling point of ethanol in comparison to methoxyethane. [1]
30. (a) State Raoult's law for a solution of volatile liquids. [1]
- (b) Under what conditions, a solution shows negative deviation from Raoult's law? [1]
- (c) Classify the following solutions into positive and negative deviation from Raoult's law : [1]
- (i)  $\text{CHCl}_3 + \text{C}_6\text{H}_6$  (ii)  $\text{CH}_3\text{COCH}_3 + \text{C}_2\text{H}_5\text{OH}$

## SECTION - D

31. Chemical kinetics is the study of chemical reactions with respect to reaction rates, effect of various variables rearrangement of atoms and formation of intermediates. The rate of reaction is concerned with decrease in concentration of reactant or increase in the concentration of products per unit time. It can be expressed as instantaneous rate at a particular instant of time and average rate over a large interval of time. A number of factors such as temperature, concentration of reactants, catalyst, affect the rate of a reaction. The integrated rate equations are different for the reactions of different reactions order. We shall determine these equations only for zero-and first-order chemical reaction. @AAKASH\_TEST\_PAPERS\_2024

Corporate Office : Aakash Tower, 8, Pusa Road, New Delhi-110005. Ph.: 011-47623456

(57)

## Chemistry (Class XII)

## Model Test Paper-3

The half-life of a reaction is the time in which the concentration of the reactant is reduced to one half of its initial concentration. It is represented as  $t_{1/2}$ .

- (a) What is the unit of rate of reaction for first-order reaction? [1]  
 (b) What is the slope of concentration of reactant vs time graph for zero-order reaction? [1]  
 (c) A first-order reaction is found to have a rate constant,  $K = 5.5 \times 10^{-14} \text{ s}^{-1}$ . Find the half-life of the reaction. [2]

## 32. Case Study:

Nomenclature is important in coordination chemistry to remove the ambiguity for formulas and names on the recommendation of IUPAC.

To explain the nature of bonding in coordination compounds, many approaches have been put forward like Valence Bond Theory (VBT), Crystal Field Theory (CFT), Ligand Field Theory (LFT) and Molecular Orbital Theory (MOT).

- (a) Write the IUPAC name of the complex compound of  $[\text{Co}(\text{en})_2\text{ClBr}]$ . [1]  
 (b) Is  $[\text{CoF}_6]^{3-}$  a high spin or low spin complex? [1]  
 (c) Calculate the CFSE of the complex compound  $[\text{Cr}(\text{H}_2\text{O})_6]\text{Cl}_2$ . [2]

## SECTION - E

## 33. Write structures of the products of the following reactions.

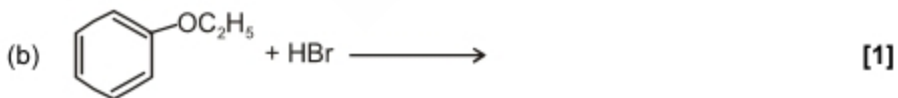
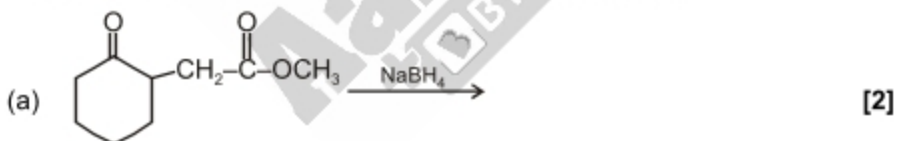

## OR

An organic compound with molecular formula  $\text{C}_9\text{H}_{10}\text{O}$  forms 2,4-DNP derivative, reduces Tollen's reagent and undergoes Cannizzaro reaction. On vigorous oxidation, it gives 1,2-benzenedicarboxylic acid. Identify the compound and write the reactions involved. [5]

@AAKASH\_TEST\_PAPERS\_2024

## Model Test Paper-3

## Chemistry (Class XII)

34. (a) Carry out the following conversions: [3]
- 2-Chloropropane to propanal
  - Benzaldehyde to benzene
  - Benzamide to toluene
- (b) Give one example each of [2]
- Gabriel phthalimide synthesis
  - Clemmensen reduction

OR

- (a) Arrange the following in the increasing order of basic strength in gaseous phase :

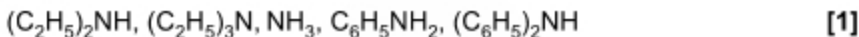

- (b) Give the structures of A, B and C in the following reactions : [2]

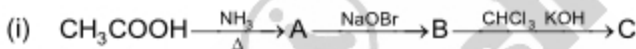

- (c) Give simple tests to distinguish between the following pairs of compounds : [2]

- Benzoic acid and benzaldehyde
- Butanone and butan-1-ol

35. (a) Complete the following reactions :



- (b) Answer the following: [3]

- Silver atom has completely filled  $d$ -orbitals ( $4d^{10}$ ) in its ground state. How can you say that it is a transition element?
- Which of the  $3d$  series transition metals exhibits the largest number of oxidation state and why?
- Which is a stronger reducing agent between  $\text{Cr}^{2+}$  and  $\text{Fe}^{2+}$  and why?

@AAKASH\_TEST\_PAPERS\_2024

Corporate Office : Aakash Tower, 8, Pusa Road, New Delhi-110005. Ph.: 011-47623456

(59)

## Chemistry (Class XII)

## Model Test Paper-3

OR

(a) Complete the following reactions: [2]

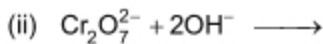
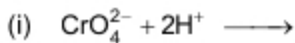

(b) (i) Name a member of the Lanthanoid series which is well known to exhibit +4 oxidation state. [3]

(ii) Actinoid contraction is greater from element to element as compared to Lanthanoid contraction. Why?

(iii) Explain why  $\text{Cu}^+$  ion is not stable in aqueous solutions.

ATDB.uno

Aakash  
+BYJU'S

@AAKASH\_TEST\_PAPERS\_2024

Corporate Office : Aakash Tower, 8, Pusa Road, New Delhi-110005. Ph.: 011-47623456  
(60)

# Model Test Papers

# BIOLOGY

ATDB.uno



@AAKASH\_TEST\_PAPERS\_2024



ATDB.uno

@AAKASH\_TEST\_PAPERS\_2024

## Model Test Paper-1

## Biology (Class XII)

Time: 3 Hours

**Model Test Paper-1**  
for  
School/Board Exams

M.M.: 70

**Biology****Topics:** Complete Syllabus of Class XII**General Instructions:**

1. All questions are compulsory.
2. The question paper has five sections and 33 questions. All questions are compulsory.
3. Section-A has 16 questions of 1 mark each; Section-B has 5 questions of 2 marks each; Section-C has 7 questions of 3 marks each; Section-D has 2 case-based questions of 4 marks each; and Section-E has 3 questions of 5 marks each.
4. There is no overall choice. However, internal choices have been provided in some questions. A student has to attempt only one of the alternatives in such questions.
5. Wherever necessary, neat and properly labeled diagrams should be drawn.

**SECTION - A**

1. Fusion of male and female gametes leading to the formation of zygote is termed as [1]
  - (1) Parturition
  - (2) Gestation
  - (3) Gametogenesis
  - (4) Fertilisation
2. Function of secretions of bulbourethral glands in humans is to [1]
  - (1) Secrete the entire seminal plasma
  - (2) Lubricate the penis
  - (3) Store and nourish the sperms
  - (4) Secrete androgens

@AAKASH\_TEST\_PAPERS\_2024

Corporate Office : Aakash Tower, 8, Pusa Road, New Delhi-110005. Ph.: 011-47623456  
(61)

## Biology (Class XII)

## Model Test Paper-1

3. Which of the following statements are **correct** with respect to post-fertilization development in a typical angiosperm? [1]
- Central cell of embryo sac develops into endosperm.
  - Ovary matures into fruit.
  - Zygote develops into perisperm.
  - Ovules mature into seed.
- (1) b and c  
(2) a, b and d  
(3) a and c  
(4) b, c and d
4. Which barrier of innate immunity includes mucus coating of the epithelium lining the respiratory tract? [1]
- Physical barrier
  - Physiological barrier
  - Cellular barrier
  - Cytokine barrier
5. Administration of antitoxin can be considered as [1]
- Active immunisation
  - Passive immunisation
  - Auto immunity
  - Innate immunity
6. A scientist wants to create a colony of *E. coli* which possesses the plasmid pBR322 that is sensitive to ampicillin. Which restriction site would he use to ligate a foreign DNA? [1]
- Pst*I
  - Cla*I
  - Hind*III
  - Sal*I

## Model Test Paper-1

## Biology (Class XII)

7. The unequivocal proof that DNA is a genetic material came from the experiments of [1]
- (1) Frederick Griffith
  - (2) Meselson and Stahl
  - (3) Francois Jacob and Jacques Monod
  - (4) Alfred Hershey and Martha Chase
8. A woman is in the second trimester of her pregnancy. Read the following statements and choose the **incorrect** one w.r.t. this woman who is seeking for MTP. [1]
- (1) She can go ahead with the MTP on the opinion of two registered medical practitioners.
  - (2) MTP can be carried out with the opinion of just one registered medical practitioner.
  - (3) She can seek for MTP on the ground that there is a chance of a physical/mental abnormality in the child.
  - (4) MTP can be on the ground that the pregnancy would involve a risk to her life.
9. Which among the following statements is true for Law of Dominance? [1]
- (1) It explains that all the parental characters are expressed in  $F_1$  generation.
  - (2) Proposed by T. H. Morgan.
  - (3) Stated that characters are controlled by discrete units called factors.
  - (4) Universally applicable.
10. Which among the given below is an *ex-situ* conservation strategy of organisms? [1]
- (1) Sacred groves
  - (2) National parks
  - (3) Wildlife sanctuaries
  - (4) Wildlife safari parks

@AAKASH\_TEST\_PAPERS\_2024

Corporate Office : Aakash Tower, 8, Pusa Road, New Delhi-110005. Ph.: 011-47623456  
(63)

## Biology (Class XII)

## Model Test Paper-1

11. In which of the following types of population interactions only one species benefits? [1]
- (1) Competition
  - (2) Amensalism
  - (3) Parasitism
  - (4) Mutualism
12. Which of the given is not considered as a part of histone octamer? [1]
- |                           |             |
|---------------------------|-------------|
| a. Linker DNA             | b. Arginine |
| c. H <sub>1</sub> histone | d. Lysine   |
- (1) a and d
  - (2) b and d
  - (3) a, c and d
  - (4) a and c
13. **Assertion (A)** : Turner's syndrome is an example of trisomy. [1]  
**Reason (R)** : The genetic complement of an individual who is afflicted with Turner's syndrome is 44 + XO.
- (1) Both (A) and (R) are true and (R) is the correct explanation of (A)
  - (2) Both (A) and (R) are true and (R) is not the correct explanation of (A)
  - (3) (A) is true but (R) is false
  - (4) (A) is false but (R) is true
14. **Assertion (A)** : DNA is chemically less reactive and structurally more stable than RNA. [1]  
**Reason (R)** : DNA has deoxyribose sugar along with that, thymine is present in the place of uracil.
- (1) Both (A) and (R) are true and (R) is the correct explanation of (A)
  - (2) Both (A) and (R) are true and (R) is not the correct explanation of (A)
  - (3) (A) is true but (R) is false
  - (4) (A) is false but (R) is true

@AAKASH\_TEST\_PAPERS\_2024

Corporate Office : Aakash Tower, 8, Pusa Road, New Delhi-110005. Ph.: 011-47623456  
(64)

## Model Test Paper-1

## Biology (Class XII)

15. **Assertion (A)** : *Saheli* is a non-steroidal oral contraceptive pill. [1]

**Reason (R)** : It has high contraceptive value and to be taken daily by the female.

- (1) Both (A) and (R) are true and (R) is the correct explanation of (A)  
(2) Both (A) and (R) are true and (R) is not the correct explanation of (A)  
(3) (A) is true but (R) is false  
(4) (A) is false but (R) is true
16. **Assertion (A)** : The essence of Darwinian theory is natural selection. [1]
- Reason (R)** : There has been a gradual evolution of life according to Darwin.
- (1) Both (A) and (R) are true and (R) is the correct explanation of (A)  
(2) Both (A) and (R) are true and (R) is not the correct explanation of (A)  
(3) (A) is true but (R) is false  
(4) (A) is false but (R) is true

## SECTION - I

17. Name the group of chemicals obtained from the plant to which the part shown in the diagram belongs. [1]

State the location of its receptors in the human body and one mode of consumption of these drugs. [1]



18. Draw a diagram of mature female gametophyte of a typical angiosperm and label any four of its parts. [2]
19. Define allergy. Name the substance which cause allergy and what type of antibodies are produced during allergic reactions? [2]

@AAKASH\_TEST\_PAPERS\_2024

## Biology (Class XII)

## Model Test Paper-1

20. Define homologous structures. Give two examples. [2]
21. The diagram given below represents a typical biogas plant. Identify the parts labelled as A and B, also mention the name of institutes involved in development of technology of biogas production. [2]

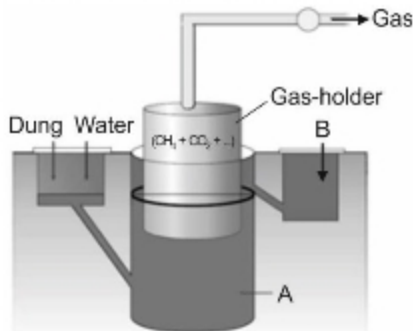

OR

Name the organism which is involved in the production of 'Swiss cheese'. Provide the reason for the formation of large holes in this cheese. [1 + 1]

## SECTION - C

22. Explain in brief, how a bacterial cell can be made 'competent' to take up rDNA and the reason behind this. [3]
23. Construct a pyramid of number in a grassland ecosystem. Label its three trophic levels. Is the pyramid upright or inverted? Justify your answer. [3]
24. (a) Hotspots are a type of *in-situ* conservation, write any two key criteria for determining a hotspot.
- (b) Name any two hotspots found in India.
- (c) Why are the hotspots placed under *in-situ* conservation? [3]
25. If a foreign gene of interest is inserted at *PvuI* site of pBR322 vector then what will happen to recombinants? How will you select recombinants from a colony of bacteria containing both transformants and non-transformants? [3]
26. Explain cancer and how cancerous cell is different from the normal cell? Elaborate the methods of cancer detection. [3]

OR

With the help of flow chart, represent the life cycle of a malarial parasite. [2024]

**Model Test Paper-1****Biology (Class XII)**

27. Name the technique which is carried out in a single test tube simply by mixing DNA with a set of reagents and placing the tube in a thermal cycler that enables amplification of gene of interest. Describe the basic steps involved in the amplification of gene of interest with the help of a diagram. [3]
28. (a) Name any two cyanobacteria which serve as an important biofertilisers.  
(b) What is the mode of nutrition in cyanobacteria?  
(c) Discuss their role as biofertilisers. [3]

**SECTION - D**

29. The bacteria shown in the below given diagram is used to produce a product by genetic engineering and is given to patients having myocardial infarction.



- (a) Identify the bacteria and the product. [1]  
(b) How does this product help the patients? [1]  
(c) One such type of bacterium was also involved in the discovery of the first antibiotic. Which was that bacterium and the antibiotic discovered? How had this discovery made? [2]

**OR**

The given bacteria is also used for proposing 'Transforming Principle'. Who gave this principle? What is the conclusion of 'Transforming Principle' experiment? [2]

@AAKASH\_TEST\_PAPERS\_2021

Corporate Office : Aakash Tower, 8, Pusa Road, New Delhi-110005. Ph.: 011-47623456  
(67)

## Biology (Class XII)

## Model Test Paper-1

30. A geneticist used a plasmid for cloning, that has a tetracycline resistance gene and the *lac Z* gene. The *lac Z* gene codes for enzyme  $\beta$ -galactosidase. The geneticist inserts a piece of foreign DNA into a restriction site that is located within the *lac Z* gene and transforms the bacteria with the plasmid.

Then, he plated those bacterial culture on a agar medium and obtained the following scenario.

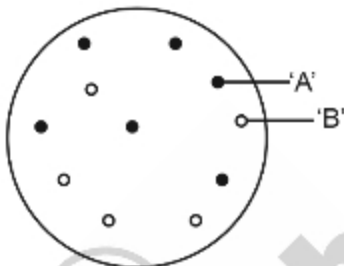

- (a) Explain how the geneticist can identify bacteria that contain a copy of a plasmid with the foreign DNA. [2]
- (b) Suppose that this geneticist discovers a new restriction enzyme in the bacterium *Aeromonas ranidae*. This restriction enzyme is the first to be isolated from this bacterial species. Using the standard convention for abbreviating restriction enzymes, give this new restriction enzyme a name. [2]

OR

A girl 'X' is of 15 years and suffers from Type-1 diabetes. This type of diabetes develops in people younger than age 20, though it persists throughout life. This is the most common type of diabetes in northern Europe, especially in Finland where nearly 1% of the population develops this diabetes by 15 years of age. In the U.S., it is 1.5-2 times more common in whites than in African American or Asian populations.

A doctor prescribed 'X' to get regular injections of insulin. 'X' read about it and came to know that insulin used for diabetes was earlier extracted from pancreas of slaughtered cattle and pigs, but now RDT *i.e.*, recombinant DNA technology is used to make insulin. @AAKASH\_TEST\_PAPERS\_2024

## Model Test Paper-1

## Biology (Class XII)

- (a) Why is insulin extracted from pancreas of slaughtered animals are not used anymore? [1]
- (b) Describe the maturation of insulin with the help of a diagram. [1½]
- (c) Explain the process of formation of humulin by an American company Eli Lilly in 1983. [1½]

## SECTION - E

31. Explain the hormonal control of spermatogenesis and give schematic representation of the process called spermatogenesis. [5]

OR

- (a) Draw and label the *E. coli* cloning vector pBR322 showing the various restriction sites. [3]
- (b) What is gene therapy? When and why the first gene therapy was given to a four-year old girl? [2]
32. Population interaction between two species A and B are given below.

Species A	Species B
(i) +	+
(ii) +	0

- (i) +                      +
- (ii) +                     0
- (a) Identify the type of interaction given in (i) and (ii) along with an example of each. [2]
- (b) For the first (i) type of interaction, it is said that in some cases participating populations co-evolve. Justify the statement. [3]

OR

Dominance is not an autonomous feature of a gene or the product. It depends upon the gene product and the phenotype we choose to examine when a gene shows pleiotropy. Explain this hypothesis by taking example of starch synthesis in garden pea. [5]

33. (a) What is metastasis? [1]
- (b) What are the characteristic symptoms of withdrawal syndrome? [1]

**Biology (Class XII)****Model Test Paper-1**

- (c) Name a drug which is an effective sedative and painkiller. [1]
- (d) What is heroin? Mention the locations where opioid receptors are present in the human body. [2]

**OR**

A modern pathology laboratory uses non-conventional methods of diagnosis for detecting a disease early.

- (a) Which method that they use is based on the principle of antigen-antibody interaction? [1]
- (b) Describe the procedure of using ssDNA or RNA probes. [2]
- (c) Name any two conventional methods of diagnosis which are not as helpful for the early detection of diseases. [2]

ATDB.uno

Aakash  
+ BYJU'S

@AAKASH\_TEST\_PAPERS\_2024

Corporate Office : Aakash Tower, 8, Pusa Road, New Delhi-110005. Ph.: 011-47623456  
(70)

## Model Test Paper-2

## Biology (Class XII)

Time: 3 Hours

**Model Test Paper-2**  
for  
School/Board Exams

M.M.: 70

**Biology****Topics:** Complete Syllabus of Class XII**General Instructions:**

1. All questions are compulsory.
2. The question paper has five sections and 33 questions. All questions are compulsory.
3. Section-A has 16 questions of 1 mark each; Section-B has 5 questions of 2 marks each; Section-C has 7 questions of 3 marks each; Section-D has 2 case-based questions of 4 marks each; and Section-E has 3 questions of 5 marks each.
4. There is no overall choice. However, internal choices have been provided in some questions. A student has to attempt only one of the alternatives in such questions.
5. Wherever necessary, neat and properly labeled diagrams should be drawn.

**SECTION - A**

1. How many seminiferous tubules are possibly present in each testis of human male? [1]  
(1) 1-250  
(2) 250-750  
(3) 1-10  
(4) 100-500
2. Which ART is preferred in the infertility cases due to very low sperm count in the male ejaculate? [1]  
(1) ZIFT  
(2) GIFT  
(3) IUT  
(4) AI

@AAKASH\_TEST\_PAPERS\_2024

Corporate Office : Aakash Tower, 8, Pusa Road, New Delhi-110005. Ph.: 011-47623456

(71)

## Biology (Class XII)

## Model Test Paper-2

3. How many nuclei are involved in double fertilization in a typical angiosperm? [1]
- (1) Two (2) Seven  
(3) Five (4) Eight
4. Cutting of a double-stranded DNA molecule at palindromic sequences in the DNA is the action of [1]
- (1) Exonuclease  
(2) Restriction endonuclease  
(3) Ligase  
(4) Polymerase
5. Contraceptive method that contains non-steroidal preparation is [1]
- (1) LNG-20  
(2) Saheli  
(3) Injectable  
(4) Implants
6. The first transgenic cow "Rosie" produced human protein-enriched milk which contained how many grams of protein? [1]
- (1) 0.4 gm/litre  
(2) 2.4 gm/litre  
(3) 12.4 gm/litre  
(4) 22.4 gm/litre
7. Select the **incorrect** statement w.r.t. phenylketonuria. [1]
- (1) It is an inborn error of metabolism.  
(2) It is inherited as autosomal recessive disorder.  
(3) The affected individual lacks a liver enzyme called phenylalanine hydroxylase that converts tyrosine into phenylalanine.  
(4) The affected individual may become mentally retarded.

@AAKASH\_TEST\_PAPERS\_2024

Corporate Office : Aakash Tower, 8, Pusa Road, New Delhi-110005. Ph.: 011-47623456

(72)

## Model Test Paper-2

## Biology (Class XII)

8. Read the statements given below and select the incorrect one. [1]
- (1) Except for hepatitis B, genital herpes, and HIV infections, other STIs are completely curable.
  - (2) MTPs are considered safe during the first trimester *i.e.*, up to 12 weeks of pregnancy.
  - (3) Progestasert and Multiload 375 are copper ions releasing IUDs.
  - (4) Periodic abstinence and coitus interruptus are natural methods of contraception.
9. Indigenous catfishes face threat of extinction due to the introduction of (A) for aquaculture purposes. Select the correct option to fill (A). [1]
- (1) Nile Perch
  - (2) *C. gariepinus*
  - (3) Cichlid fish
  - (4) *Lantana*
10. Which of the following fungal products is used as immunosuppressive agent? [1]
- (1) Citric acid
  - (2) Statins
  - (3) Cyclosporin A
  - (4) Streptokinase
11. Relationship between sea anemone and clown fish comes under the category of [1]
- (1) Commensalism
  - (2) Amensalism
  - (3) Mutualism
  - (4) Competition
12. All of the following options represents the limitations of ecological pyramids, **except** [1]
- (1) It does not take into account the same species belonging to two or more trophic levels.
  - (2) It accommodates saprophytes.
  - (3) It assumes a simple food chain.
  - (4) It does not accommodate a food web.

@AAKASH\_TEST\_PAPERS\_2024

Corporate Office : Aakash Tower, 8, Pusa Road, New Delhi-110005. Ph.: 011-47623456

(73)

## Biology (Class XII)

## Model Test Paper-2

13. **Assertion (A)** : Genetic code is said to be degenerate. [1]

**Reason (R)** : Some amino acids are coded by more than one codon.

- (1) Both (A) and (R) are true and (R) is the correct explanation of (A)  
(2) Both (A) and (R) are true and (R) is not the correct explanation of (A)  
(3) (A) is true but (R) is false  
(4) (A) is false but (R) is true
14. **Assertion (A)** : DNA is chemically less reactive and structurally more stable than RNA. [1]

**Reason (R)** : RNA has ribose sugar along with uracil.

- (1) Both (A) and (R) are true and (R) is the correct explanation of (A)  
(2) Both (A) and (R) are true and (R) is not the correct explanation of (A)  
(3) (A) is true but (R) is false  
(4) (A) is false but (R) is true
15. **Assertion (A)** : The linking of a restriction enzyme with the plasmid vector became possible with the enzyme DNA ligase. [1]

**Reason (R)** : DNA ligase acts on cut DNA molecules and joins their ends.

- (1) Both (A) and (R) are true and (R) is the correct explanation of (A)  
(2) Both (A) and (R) are true and (R) is not the correct explanation of (A)  
(3) (A) is true but (R) is false  
(4) (A) is false but (R) is true
16. **Assertion (A)** : The foetal ejection reflex triggers the release of relaxin from the maternal pituitary. [1]

**Reason (R)** : Relaxin is produced in the later phase of pregnancy.

- (1) Both (A) and (R) are true and (R) is the correct explanation of (A)  
(2) Both (A) and (R) are true and (R) is not the correct explanation of (A)  
(3) (A) is true but (R) is false  
(4) (A) is false but (R) is true

@AAKASH\_TEST\_PAPERS\_2024

Corporate Office : Aakash Tower, 8, Pusa Road, New Delhi-110005. Ph.: 011-47623456

(74)

## Model Test Paper-2

## Biology (Class XII)

## SECTION - B

17. Name the type of immunity a child is born with. How does it differ from the immunity he/she receives from its mother's milk? [2]
18. Explain the Verhulst Pearl Logistic growth and write down the correct mathematical expression for this type of growth pattern. [2]
19. Identify the compound given in the diagram below.

This compound is obtained from which plant and how are the drugs derived from this compound generally consumed? [2]

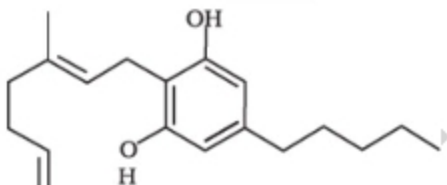

20. Write the five factors which affect Hardy-Weinberg equilibrium. [2]
21. We should save our threatened plant and animal species to conserve our biodiversity. [2]
- Mention any two approaches for the same and their examples. [2]

OR

Briefly describe two microbes used as biocontrol agents to control pest and pathogen. [2]

## SECTION - C

22. (a) What is transformation? [1]
- (b) What happens when the recombinant DNA is inserted at *Bam*HI recognition site within the coding sequence of tetracycline-resistance gene of vector pBR322? [1]
- (c) What is the process occurring in (b) called? [1]

@AAKASH\_TEST\_PAPERS\_2024

Corporate Office : Aakash Tower, 8, Pusa Road, New Delhi-110005. Ph.: 011-47623456

(75)

## Biology (Class XII)

## Model Test Paper-2

23. (a) Define linkage. [1]  
(b) Which equation can be used to calculate net primary productivity. [1]  
(c) Define secondary productivity. [1]

24.

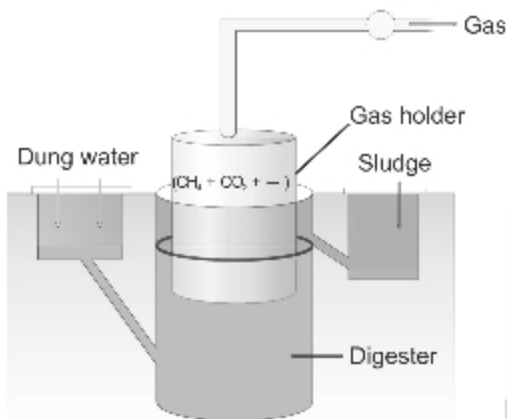

Fig : A typical biogas plant

Observe the above diagram of a typical biogas plant and answer the following questions.

- (a) Write down the name as well as habitat of the organisms responsible for biogas production.  
(b) Name the gas which is shown missing in the mixture of gases present in gas holder.  
(c) Name the predominant or major gas of biogas mixture. [3]
25. (a) Name the nematode that infects the roots of tobacco plants and cause a great reduction in yield. [1]  
(b) Explain the method by which transgenic tobacco plants are protected from parasites. [2]

@AAKASH\_TEST\_PAPERS\_2024

Corporate Office : Aakash Tower, 8, Pusa Road, New Delhi-110005. Ph.: 011-47623456  
(76)

## Model Test Paper-2

## Biology (Class XII)

26. How is AIDS transferred from one person to another? Name a diagnostic test for it and state its underlying principle. [3]

OR

A person is suffering from an infectious disease caused by helminths. Name any two helminthic diseases he/she may be suffering from, its causative organism and mode of transmission.

27. The image below depicts a technique for amplification of gene of interest.

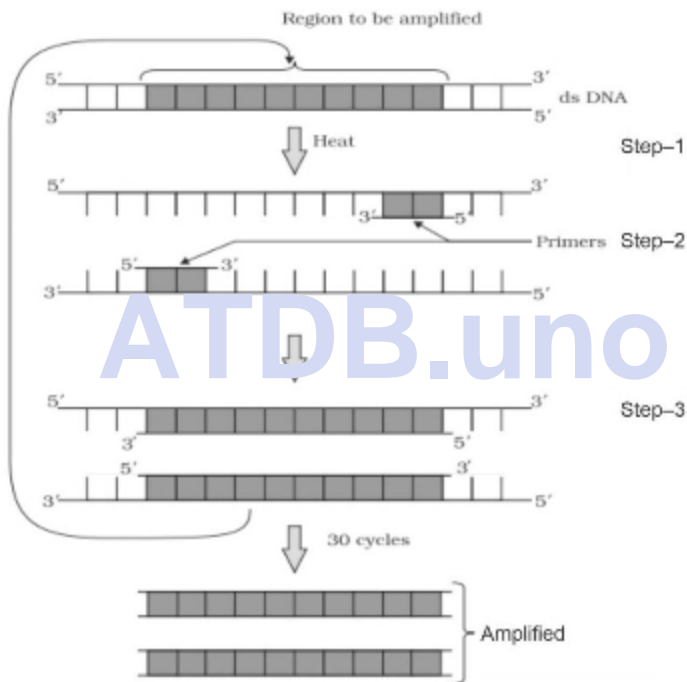

- (a) Which bonds are broken while moving from step-1 to step-2 in the given technique? [1]
- (b) How many molecules of gene of interest will be generated after 10 cycles of this technique? [1]
- (c) Name the step in which DNA polymerase and deoxyribonucleotides are required. [1]

@AAKASH\_TEST\_PAPERS\_20

Corporate Office : Aakash Tower, 8, Pusa Road, New Delhi-110005. Ph.: 011-47623456

(77)

## Biology (Class XII)

## Model Test Paper-2

28. (a) Who gave species-area relationship? What does the slope of line represent?
- (b) According to Rivet Popper hypothesis, what will happen if rivets are removed from the wings of the plane?
- (c) "Loss of one species leads to the extinction of another species". Which evil quartet is defined by the above line? Explain with help of an example. [3]

## SECTION - D

29. A student prepared a slide of human blood smear showing RBCs and obtained the following observation. Based on the figure answer the following questions:

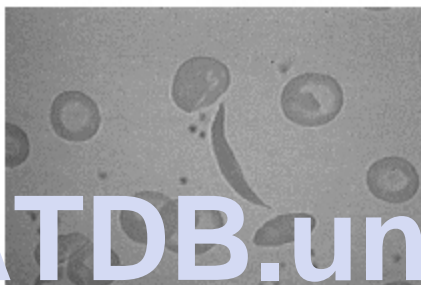

- (a) Which disorder is represented by the slide's observation? [1]
- (b) Which type of inheritance is exhibited by this trait? [1]
- (c) What is the underlying genetic cause of the disease? [2]

OR

- (c) What is the probability of children being diseased when both the parents are heterozygotes for the gene? [2]
30. 'X' studies in a government school. His parents used to scold him for that. Once he felt a strange pain in his stomach, weakness, headache as well as sustained high fever ( $39^{\circ}$  to  $40^{\circ}$ C). Identify the illness he could be suffering from and answer the following questions.
- (a) Name the microbe responsible for 'X' illness. [1]
- (b) Name the confirmatory test for this disease. [1]
- (c) Name one protozoan disease whose mode of transmission is similar to the disease by which 'X' is suffering. State the symptoms as well. [2]

## Model Test Paper-2

## Biology (Class XII)

OR

Oogenesis is the process of formation of a mature female gamete. It consists of three phases, multiplication, growth and maturation. Oogenesis is controlled by hormones namely GnRH, LH, FSH *etc.* GnRH is secreted by the hypothalamus that stimulates the anterior lobe of pituitary gland to secrete LH and FSH.

- (a) What is the function of FSH? [1]  
 (b) Which hormone induces the rupture of mature Graafian follicle? [1]  
 (c) Which cell division is involved in the formation of secondary oocyte? [1]  
 (d) When does oogenesis gets initiated in a human female? [1]

## SECTION - E

31. (i) What is adaptive radiation?  
 Explain the following with the help of suitable examples. [3]  
 (a) Adaptive radiation leading to convergent evolution.  
 (b) Adaptive radiation leading to divergent evolution.  
 (ii) Which structures are the result of convergent evolution? Give four examples. [2]

OR

Show a diagrammatic representation of various events during menstrual cycle *viz.* uterine events, ovarian hormone levels, pituitary hormone levels and ovarian events. Explain them in brief. [5]

32. Study the below given pedigree chart and answer the following questions. [5]

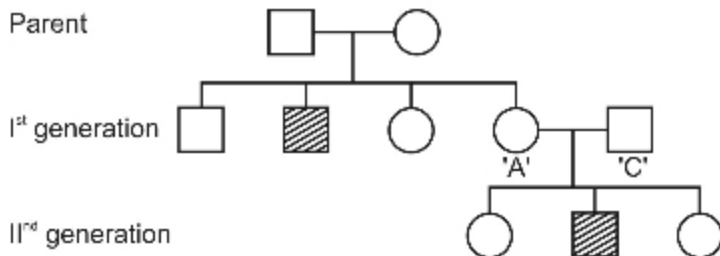

Corporate Office : Aakash Tower, 8, Pusa Road, New Delhi-110005. Ph.: 011-47623456

(79)

## Biology (Class XII)

## Model Test Paper-2

- (a) What type of trait is seen in above pedigree?
- (b) Write two examples of genetic disorders that can be shown in the given pedigree.
- (c) Write the genotype of person labelled as 'A'.
- (d) What should be the genotype of 'A' and 'C', if the 'B' also suffering from the above genetic disorder? [5]

OR

Briefly describe the salient features of genetic code. Out of the total 64 codons, for how many codons there is no t-RNA? Write their names. [5]

33. (a) Define saltation. [1½]
- (b) What is theory of spontaneous generation? [1½]
- (c) What is fitness according to Darwin? [1]
- (d) What are the two-key concepts of Darwinian Theory of evolution? [1]
- OR
- (a) Define infertility. [1]
- (b) What are measures one has to take to prevent from contracting STIs? [2]
- (c) Name two methods to assist infertile couples to have children that involve *in-vivo* and *in-vitro* fertilisation. [2]



@AAKASH\_TEST\_PAPERS\_2024

Corporate Office : Aakash Tower, 8, Pusa Road, New Delhi-110005. Ph.: 011-47623456  
(80)

## Model Test Paper-3

## Biology (Class XII)

Time: 3 Hours

**Model Test Paper-3**  
for  
School/Board Exams

M.M.: 70

**Biology****Topics:** Complete Syllabus of Class XII**General Instructions:**

1. All questions are compulsory.
2. The question paper has five sections and 33 questions. All questions are compulsory.
3. Section-A has 16 questions of 1 mark each; Section-B has 5 questions of 2 marks each; Section-C has 7 questions of 3 marks each; Section-D has 2 case-based questions of 4 marks each; and Section-E has 3 questions of 5 marks each.
4. There is no overall choice. However, internal choices have been provided in some questions. A student has to attempt only one of the alternatives in such questions.
5. Wherever necessary, neat and properly labeled diagrams should be drawn.

**SECTION - A**

1. The critical role of interstitial cells of testis in humans is to **[1]**
  - (1) Store and transport the sperms
  - (2) Secrete testicular hormones
  - (3) Act as a site for sperm maturation
  - (4) Provide nourishment to sperms
2. Select the option that mention the hormones which are produced in a women only during pregnancy. **[1]**
  - (1) hCG, relaxin and estrogens
  - (2) hPL, progesterone and hCG
  - (3) hCG, hPL and relaxin
  - (4) hPL, cortisol and relaxin

@AAKASH\_TEST\_PAPERS\_2024

Corporate Office : Aakash Tower, 8, Pusa Road, New Delhi-110005. Ph.: 011-47623456

(81)

## Biology (Class XII)

## Model Test Paper-3

3. Which of the following is water-pollinated plant? [1]
- (1) *Vallisneria*
  - (2) Water lily
  - (3) Water hyacinth
  - (4) Maize
4. If a human male ejaculates 300 million sperms during a coitus of which how many must have normal shape, size and show vigorous motility for normal fertility? [1]
- (1) 180 million
  - (2) 120 million
  - (3) 72 million
  - (4) 240 million
5. Select the correct statement w.r.t. the figure given below. [1]



- (1) It is a sterilization method of contraception.
  - (2) Mode of action is similar to that of contraceptive pills but their effective period is much longer.
  - (3) Irreversible method of contraception.
  - (4) Developed at CDRI, Lucknow, India
6. The specialised procedure to form an embryo under aseptic conditions by directly injecting the sperm into the ovum is [1]
- (1) IUI
  - (2) IUT
  - (3) GIFT
  - (4) ICSI

@AAKASH\_TEST\_PAPERS\_2024

Corporate Office : Aakash Tower, 8, Pusa Road, New Delhi-110005. Ph.: 011-47623456

(82)

## Model Test Paper-3

## Biology (Class XII)

7. Below given features are seen in persons suffering from which genetic disorder? [1]
- a. Additional copy of X chromosome      b. Only occur in males  
c. Gynaecomastia                              d. Sterile individual
- (1) Turner's syndrome                              (2) Down's syndrome  
(3) Klinefelter's syndrome                              (4) Edward's syndrome
8. Choose the **incorrect** statement w.r.t. embryonic development in human beings. [1]
- (1) After one month of pregnancy, the embryo's heart is formed.  
(2) By the end of the second month of pregnancy, the foetus develops limbs and digits.  
(3) By the end of first trimester, most of the major organ system are formed.  
(4) By the end of 12<sup>th</sup> weeks, the first movement of foetus are usually observed
9. Under which condition, there will be no change in the reading frame of mRNA? [1]
- (1) Deletion of a single base                              (2) Insertion of three bases  
(3) Insertion of two bases                              (4) Deletion of two bases
10. *Trichoderma* fungi are very common in [1]
- (1) Shoot ecosystems                              (2) Hydrothermal vents  
(3) Root ecosystems                              (4) Leaf ecosystem
11. Which of the following equations represents Verhulst-Pearl logistic growth? [1]
- (1)  $\frac{dN}{dt} = (b - d) \times N$                               (2)  $\frac{dN}{dt} = rN$   
(3)  $N_t = N_0 r^{rt}$                               (4)  $\frac{dN}{dt} = rN \left( \frac{K - N}{K} \right)$

@AAKASH\_TEST\_PAPERS\_2024

Corporate Office : Aakash Tower, 8, Pusa Road, New Delhi-110005. Ph.: 011-47623456  
(83)

## Biology (Class XII)

## Model Test Paper-3

12. Pyramid of energy is/can be [1]
- (1) Inverted
  - (2) Upright
  - (3) Spindle
  - (4) Upright or inverted
13. **Assertion (A)** : Tropics have greater biodiversity than temperate regions. [1]  
**Reason (R)** : Tropical environments receive more solar energy and are relatively more constant and predictable.
- (1) Both (A) and (R) are true and (R) is the correct explanation of (A)
  - (2) Both (A) and (R) are true and (R) is not the correct explanation of (A)
  - (3) (A) is true but (R) is false
  - (4) (A) is false but (R) is true
14. **Assertion (a)** : The DNA-dependent DNA polymerase catalyse DNA polymerisation only in one direction, i.e., 5'  $\rightarrow$  3'. [1]  
**Reason (R)** : The DNA fragments are joined by enzyme DNA ligase.
- (1) Both (A) and (R) are true and (R) is the correct explanation of (A)
  - (2) Both (A) and (R) are true and (R) is not the correct explanation of (A)
  - (3) (A) is true but (R) is false
  - (4) (A) is false but (R) is true
15. **Assertion (A)** : Placenta is a structural and functional unit between developing embryo and maternal body. [1]  
**Reason (R)** : The chorionic villi and umbilical cord interdigitated with each other to form placenta.
- (1) Both (A) and (R) are true and (R) is the correct explanation of (A)
  - (2) Both (A) and (R) are true and (R) is not the correct explanation of (A)
  - (3) (A) is true but (R) is false
  - (4) (A) is false but (R) is true

@AAKASH\_TEST\_PAPERS\_2024

Corporate Office : Aakash Tower, 8, Pusa Road, New Delhi-110005. Ph.: 011-47623456

(84)

## Model Test Paper-3

## Biology (Class XII)

16. **Assertion (A)** : Evolution is not a directed process in the sense of determinism. [1]

**Reason (R)** : Evolution is a stochastic process based on chance events in nature.

- (1) Both (A) and (R) are true and (R) is the correct explanation of (A)
- (2) Both (A) and (R) are true and (R) is not the correct explanation of (A)
- (3) (A) is true but (R) is false
- (4) (A) is false but (R) is true

## SECTION - B

17. How is active immunity different from passive immunity? Explain with the help of an example of each. [2]
18. What are flocs? How do these help in biological treatment of sewage water? [2]
19. The plant from which cocaine is obtained is native of South America. Name the plant and also mention the name of neurotransmitter to which it interferes. [2]
20. What is venereal disease and write some complications related to these diseases? [2]
21. Identify the interaction in the given figure and briefly discuss the benefit obtained by the plant and wasp. [2]

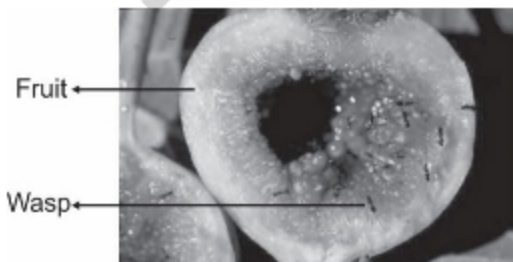

OR

Name the bioactive molecule that act as blood cholesterol-lowering agent and organism involved in production of this bioactive compound.

## SECTION - C

22. Consider the figure of a typical agarose gel electrophoresis. [3]

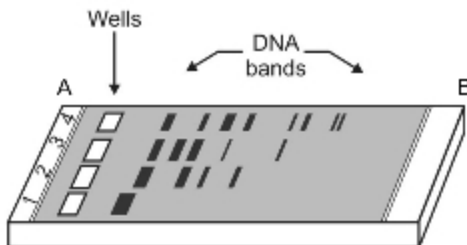

- (a) What is the charge carried by a DNA molecule and how does this help in its separation? [½]
- (b) Identify the lane 1 to lane 4 and how is lane 1 different from lane 2, 3, 4 in gel electrophoresis set up? [½]
- (c) How do one visualise the DNA in a gel and if after following each step DNA bands are not observed, then enumerate some of the reasons behind this. [2]
23. The figure given below depicts a graph between species richness and area explored.

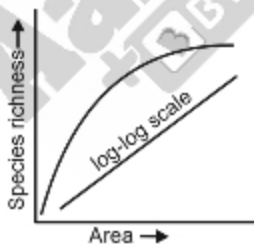

- (a) Name the scientist who gave this graph and explain his observations. [1½]
- (b) Write the equation that describes the straight line in this graph. Under what conditions, the slope of line becomes steeper? [1½]
24. What are birth and death rates? A pond had 20 lotus plants. Eight new plants were added through reproduction in one year. Calculate birth rate. [3]

## Model Test Paper-3

## Biology (Class XII)

25. A person shows a strong hypersensitivity reaction when exposed to certain substances present in air. Identify the condition. Specify its cause, symptoms and drugs used to reduce its symptoms. [3]
26. Name and describe any three methods of detection and diagnosis of cancer. [3]

OR

Describe the life cycle of *Plasmodium* in the human host.

27. 'X' complains of headache and cough. On the basis of diagnosis and certain symptoms, the doctor confirms that he is suffering from pneumonia and not from common cold. List some of the symptoms observed by doctor and its mode of transmission. Name the causative agent of pneumonia as well as common cold. [3]
28. Describe how the following factors affect the rate of decomposition. [1]
- (a) Oxygen [1]
- (b) Chemical composition of detritus [1]
- (c) Temperature [1]

29. During a diagnostic investigation, a karyotype was prepared by the doctor. Following karyotype was obtained during that investigation. Based this karyotype answer the following questions:

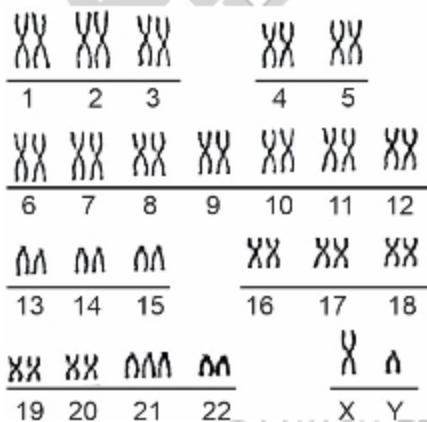

**Biology (Class XII)****Model Test Paper-3**

- (a) Which disorder is being depicted in the karyotype? [1]
- (b) What is the underlying cause of the syndrome? [1]
- (c) What are the symptoms of this disorder? [2]

**OR**

Who described this disorder for the first time and how many chromosomes are found in the affected individual?

**Case Study I:**

30. A person 'X' had the habit of smoking and his teachers as well as friends used to suggest him to avoid this habit as smoking paves the way to hard drugs. One day 'X' decided to quit smoking after he had pain in his chest region along with coughing.
- (a) How does smoking affect the oxygen delivery in the body? [2]
- (b) Smoking stimulates which gland to release adrenaline and nor-adrenaline into blood circulation? [1]
- (c) Name five disorders which is associated with smoking. [1]

**OR**

A couple wanted to have space between their children so they went to their family doctor to get some suggestions regarding types of contraceptives which they can opt for. Their doctor told them about IUDs which is one of the most widely accepted methods of contraception in India.

- (a) Name three types of IUDs which are presently available. [1]
- (b) Write the mode of action of IUDs. [2]
- (c) Give one example each of different types of IUDs. [1]

**SECTION - E**

31. In recombinant DNA technology, the cutting of DNA by restriction endonucleases results in the fragmentation of DNA. These fragments can be separated by a technique known as gel electrophoresis.
- (a) What is the basis of this technique? [2]

@AAKASH\_TEST\_PAPERS\_2024

Corporate Office : Aakash Tower, 8, Pusa Road, New Delhi-110005. Ph.: 011-47623456  
(88)

## Model Test Paper-3

## Biology (Class XII)

- (b) Name the most commonly used matrix and its source. [1]
- (c) A DNA molecule was treated with a restriction endonuclease and three fragments of size (i) 430 kb, (ii) 130 kb and (iii) 50 kb were obtained. Write the order in which these fragments will arrange themselves in the gel plate from cathode to anode after gel electrophoresis is complete. [1]
- (d) How do we isolate the desired DNA fragment from the gel? [1]

OR

Write the answer of following questions w.r.t. insulin.

- (a) Why doctors prescribing insulin injections instead of insulin tablets to diabetic person? [1]
- (b) Why is insulin not extracted from pancreas of slaughtered animals anymore? [1]
- (c) Describe the maturation of insulin with the help of a diagram. [1½]
- (d) Explain the process of formation of humulin by an American company Eli Lilly in 1983. [1½]
32. Explain the sex determination in honey bee. [5]

OR

Explain the process of DNA replication with the help of a diagram.

33. Given below is a plasmid pABCD. The restriction sites and the size of the plasmid are given.

Answer the given questions based on the figure.

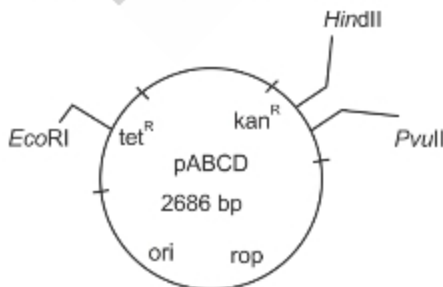

- (a) pABCD is digested using *EcoRI*. What is the recognition sequence of *EcoRI*? [1]

@AAKASH\_TEST\_PAPERS\_2024

## Biology (Class XII)

## Model Test Paper-3

- (b) *Hind*II enzyme is used to digest pABCD and a gene of interest is ligated at this site. The recombinant plasmids are then introduced in a heterologous host. This recombinant will not be able to survive in the presence of which antibiotic? [1]
- (c) If this plasmid is digested using *Eco*RI, *Hind*II and *Pvu*II, how many fragments will be obtained after complete digestion? [1]
- (d) A desirable gene is ligated at the *Eco*RI site of pABCD, and the recombinant plasmid is introduced in the bacteria. Double plating is then carried out.

The \_\_\_\_\_ will grow on the medium containing both the antibiotics, tetracycline and kanamycin.

The recombinants will grow in \_\_\_\_\_ containing medium but not on that containing \_\_\_\_\_.

OR

What is cry protein? Give the name of the organism that produces the protein. How is the human using this protein for his benefit? [5]



@AAKASH\_TEST\_PAPERS\_2024

Corporate Office : Aakash Tower, 8, Pusa Road, New Delhi-110005. Ph.: 011-47623456

(90)

# Model Test Papers

# MATHEMATICS

ATDB.uno



@AAKASH\_TEST\_PAPERS\_2024



ATDB.uno

@AAKASH\_TEST\_PAPERS\_2024

## Model Test Paper-1

## Mathematics (Class XII)

Time : 3 Hours

**Model Test Paper-1**  
for  
**School/Board Exams**

M.M. : 80

**MATHEMATICS****Topics:** Complete Syllabus of Class XII**General Instructions:**

1. This question paper contains **five sections - A, B, C, D and E**. Each part is compulsory.
2. **Section - A** has 18 **MCQ's** and **02** Assertion-Reason based questions of 1 mark each.
3. **Section - B** has 5 **Very Short Answer (VSA)-type** questions of 2 marks each.
4. **Section - C** has 6 **Short Answer (SA)-type** questions of 3 marks each.
5. **Section - D** has 4 **Long Answer (LA)-type** questions of 5 marks each.
6. **Section - E** has 3 **source based / case based / passage based/integrated units of assessment** (4 marks each) with sub parts.

**SECTION - A****(Multiple Choice Questions)**

Each question carries 1 mark

1. Principal value of  $\sin^{-1}\left(\frac{1}{2}\right)$  is [1]
- (1)  $\frac{\pi}{3}$
  - (2)  $\frac{-\pi}{3}$
  - (3)  $\frac{\pi}{6}$
  - (4)  $\frac{-\pi}{6}$

@AAKASH\_TEST\_PAPERS\_2024

Corporate Office: Aakash Tower, 8, Pusa Road, New Delhi-110005. Ph.: 011-47623456  
(91)

## Mathematics (Class XII)

## Model Test Paper-1

2. Principal value of  $\tan^{-1}(\sqrt{3})$  is [1]
- (1)  $\frac{\pi}{3}$  (2)  $\frac{\pi}{6}$   
(3)  $\frac{\pi}{2}$  (4)  $\frac{2\pi}{3}$
3. Let  $A = \{1, 2, 3\}$ , then the relation  $R = \{(1, 1), (1, 3), (3, 1)\}$  as  $A$  is [1]
- (1) Reflexive (2) Symmetric  
(3) Reflexive and symmetric (4) Equivalence
4. If  $A$  is square matrix, then  $A - A^T$  is [1]
- (1) Diagonal Matrix (2) Skew-Symmetric matrix  
(3) Symmetric Matrix (4) Null matrix always
5. In an LPP, the objective function is always [1]
- (1) Cubic (2) Quadratic  
(3) Linear (4) Constant
6. The optimal value of the objective function  $Z = ax + by$  may or may not exist, if the feasible region for an LPP is [1]
- (1) Circle (2) Polygon  
(3) Bounded (4) Unbounded
7. Derivative of  $\cot^{-1}(2x)$  w.r.t.  $x$  is [1]
- (1)  $\frac{-1}{1+x^2}$  (2)  $\frac{-2x}{1+x^2}$   
(3)  $\frac{-2}{1+4x^2}$  (4)  $\frac{2}{1+x^2}$
8. Derivative of  $\sin^{-1}(2x)$  w.r.t.  $x$  is [1]
- (1)  $\frac{1}{\sqrt{1-4x^2}}$  (2)  $\frac{2}{\sqrt{1-4x^2}}$   
(3)  $\frac{1}{\sqrt{1-2x^2}}$  (4)  $\frac{2}{\sqrt{1-x^2}}$

@AAKASH\_TEST\_PAPERS\_2024

## Model Test Paper-1

## Mathematics (Class XII)

9. If  $A = \begin{bmatrix} 2 & -1 & 3 \\ -4 & 5 & 1 \end{bmatrix}$  and  $B = \begin{bmatrix} 2 & 3 \\ 4 & -2 \\ 1 & 5 \end{bmatrix}$ , then [1]

- (1) Only  $BA$  is defined (2) Only  $AB$  is defined  
(3) Both  $AB$  and  $BA$  are defined (4) Both  $AB$  and  $BA$  are not defined

10. In an LPP if the objective function  $Z = ax + by$  has the same maximum value on two corner points of the feasible region, then every point on the line segment joining these two points give the same [1]

- (1) Minimum value (2) Mean value  
(3) Maximum value (4) Upper limit value

11. Corner points of the feasible region for an LPP are  $(0, 2)$ ,  $(3, 0)$ ,  $(6, 0)$ ,  $(6, 8)$  and  $(0, 5)$ . Let  $F = 4x + 6y$  be the objective function. Maximum of  $F$  – Minimum of  $F$  = [1]

- (1) 60 (2) 48  
(3) 42 (4) 18

12. Matrix  $A$  and  $B$  are inverse of each other only, when [1]

- (1)  $AB = BA = O$  (2)  $AB = O, BA = I$   
(3)  $AB = BA = I$  (4)  $AB \neq BA$

13. Value of derivative of  $|-x|$  at  $x = 3$  is [1]

- (1)  $-1$  (2)  $0$   
(3)  $1$  (4)  $-3$

14. Value of derivative of  $|\cos x|$  at  $x = \frac{3\pi}{4}$  is [1]

- (1)  $\frac{1}{\sqrt{2}}$  (2)  $-\frac{1}{\sqrt{2}}$   
(3)  $1$  (4)  $-1$

@AAKASH\_TEST\_PAPERS\_2024

Corporate Office: Aakash Tower, 8, Pusa Road, New Delhi-110005. Ph.: 011-47623456  
(93)

## Mathematics (Class XII)

## Model Test Paper-1

15. Which of the following functions is always decreasing in  $\left(0, \frac{\pi}{2}\right)$ ? [1]
- (1)  $\sin x$  (2)  $\tan x$   
(3)  $\cos x$  (4)  $\cos 3x$
16. Value of  $a_{11} + a_{22} + a_{33}$  if matrix  $A = [a_{ij}]_{3 \times 3}$  where [1]
- $$a_{ij} = \begin{cases} |i-j| & ; i < j \\ 2i+j & ; i \geq j \end{cases}$$
- (1) 0 (2) 18  
(3) 12 (4) 9
17. Value of  $a_{12} + a_{21}$  if matrix  $A$  is skew symmetric matrix, is (where  $a_{ij}$  represents element of  $i^{\text{th}}$  row and  $j^{\text{th}}$  column) [1]
- (1) 2 (2) 0  
(3) -2 (4) Can't determine
18. The function  $\frac{1}{1+x^2}$  is decreasing in the interval [1]
- (1)  $(-\infty, -1]$  (2)  $(-\infty, 0]$   
(3)  $[1, \infty)$  (4)  $(0, \infty)$

## ASSERTION-REASON BASED QUESTIONS

In the following questions, a statement of assertion (A) is followed by a statement of Reason (R). Choose the correct answer out of the following choices.

- (1) Both A and R are true and R is the correct explanation of A.  
(2) Both A and R are true but R is not the correct explanation of A.  
(3) A is true but R is false.  
(4) A is false but R is true.

@AAKASH\_TEST\_PAPERS\_2024

Corporate Office: Aakash Tower, 8, Pusa Road, New Delhi-110005. Ph.: 011-47623456  
(94)

## Model Test Paper-1

## Mathematics (Class XII)

19. **Assertion (A)** : Principal value of  $\cos^{-1}(1)$  is  $\pi$ . [1]

**Reason (R)** : Value of  $\cos 0^\circ$  is 1.

20. **Assertion (A)** : Angle between  $\hat{i} + \hat{j}$  and  $\hat{i}$  is  $45^\circ$ . [1]

**Reason (R)** :  $\hat{i} + \hat{j}$  is equally inclined both  $\hat{i}$  and  $\hat{j}$  and the angle between  $\hat{i}$  and  $\hat{j}$  is  $90^\circ$ .

## SECTION - B

(This section comprises of very short answer type questions (VSA) of 2 marks each)

21. Solve  $(1-x^2)\frac{dy}{dx} + xy = ax$ . [2]

OR

Find the general solution of differential equation  $\frac{dy}{dx} = \frac{y}{x-y}$ .

22. Find a vector whose magnitude is 3 units and which is perpendicular to each of the vectors  $\vec{a} = 3\hat{i} + \hat{j} - 4\hat{k}$  and  $\vec{b} = 6\hat{i} + 5\hat{j} - 2\hat{k}$ . [2]

23. Find the sum of the vectors:

$$\vec{a} = \hat{i} - 2\hat{j} + \hat{k}, \vec{b} = -2\hat{i} + 4\hat{j} + 5\hat{k} \text{ and } \vec{c} = \hat{i} - 6\hat{j} - 7\hat{k}. \quad [2]$$

OR

If  $\vec{a} = x\hat{i} + 2\hat{j} - z\hat{k}$  and  $\vec{b} = 3\hat{i} - y\hat{j} + \hat{k}$  are two equal vectors, then write the value of  $x + y + z$ .

24. If  $A$  is a square matrix such that  $A^2 = I$ , then find the simplified value of  $(A - I)^3 + (A + I)^3 - 7A$ . [2]

25. Let  $\vec{a} = \hat{i} + \hat{j} + \hat{k}$ ,  $\vec{b} = 4\hat{i} - 2\hat{j} + 3\hat{k}$  and  $\vec{c} = \hat{i} - 2\hat{j} + \hat{k}$ . Find a vector of magnitude 6 units, which is parallel to the vector  $2\vec{a} - \vec{b} + 3\vec{c}$ . [2]

## Mathematics (Class XII)

## Model Test Paper-1

## SECTION - C

(This section comprises of short answer type questions (SA) of 3 marks each)

26. Evaluate  $\int \frac{\tan x + \tan^3 x}{1 + \tan^3 x} dx$ . [3]

27. Solve the following differential equation  $\frac{dy}{dx} = x \sec^2 y$ . [3]

OR

Show that the differential equation  $(x - y) \frac{dy}{dx} = x + 2y$  is homogeneous and hence find the general solution of this differential equation.

28. Show that the function  $f : R \rightarrow \{x \in R : -1 < x < 1\}$  defined by

$$f(x) = \frac{x}{1 + |x|}, x \in R \text{ is one-one function. [3]}$$

If  $A = \{1, 2, 3\}$ ,  $B = \{4, 5, 6, 7\}$  and  $f = \{(1, 4), (2, 5), (3, 6)\}$  is a function from  $A$  to  $B$ . State whether  $f$  is one-one or not.

29. Find the area bounded by the parabola  $y = x^2 - 1$ ,  $x$ -axis and the line  $y = 8$ . [3]

OR

Find the area bounded by the curve  $y^2 = 4ax$  and the line  $y = 2a$  and  $y$ -axis.

30. Show that the function  $f(x) = x^3 - 3x^2 + 6x - 100$  is increasing on  $R$ . [3]

31. Find the foot of perpendicular drawn from the point  $P(2, -3, 4)$  to the plane  $x + 2y + 2z = 13$ . [3]

## SECTION - D

(This section comprises of long answer type questions (LA) of 5 marks each)

32. Evaluate the value of  $\int_0^\pi \frac{x}{1 + \sin x} dx$ . [5]

@AAKASH\_TEST\_PAPERS\_2024

Corporate Office: Aakash Tower, 8, Pusa Road, New Delhi-110005. Ph.: 011-47623456 (96)

## Model Test Paper-1

## Mathematics (Class XII)

33. Show that the lines  $\frac{x+1}{3} = \frac{y+3}{5} = \frac{z+5}{7}$  and  $\frac{x-2}{1} = \frac{y-4}{3} = \frac{z-6}{5}$  intersect. Also, find their point of intersection. [5]

OR

Find the vector equation of the line passing through (1, 2, 3) and parallel to the planes  $\vec{r} \cdot (\hat{i} - \hat{j} + 2\hat{k}) = 5$  and  $\vec{r} \cdot (3\hat{i} + \hat{j} + \hat{k}) = 6$ . Hence, find the Cartesian equation also.

34. Find the shortest distance between the lines  $\frac{x+1}{7} = \frac{y+1}{-6} = \frac{z+1}{1}$  and  $\frac{x-3}{1} = \frac{y-5}{-2} = \frac{z-7}{1}$ . [5]

OR

Find the vector and Cartesian equation of the plane which passes through the point (5, 2, -1) and which is perpendicular to the line with direction ratios (2, 3, -1).

35. Evaluate  $\int_0^{3/2} |x \cos \pi x| dx$  [5]

## SECTION - E

(This section comprises of 3 case study/passage-based questions of 4 marks each with two sub-parts. First two case study questions have three sub-parts (i), (ii), (iii) of marks 1, 1, 2 respectively. The third case study question has two sub-parts of 2 marks each)

36. Suppose the floor of a hotel is made up of mirror polished Salvatore stone. There is a large crystal chandelier attached to the ceiling of the hotel room. Consider the floor of the hotel room as plane having the equation  $x - y + z = 4$  and the crystal chandelier is suspended at the point (1, 0, 1).

@AAKASH\_TEST\_PAPERS\_2024

Corporate Office: Aakash Tower, 8, Pusa Road, New Delhi-110005. Ph.: 011-47623456  
(97)

## Mathematics (Class XII)

## Model Test Paper-1



- (i) Find the length of the perpendicular from the point  $(1, 0, 1)$  to plane  $x - y + z = 4$ . [1]

(1)  $\frac{2}{\sqrt{3}}$  units

(2)  $\frac{4}{\sqrt{3}}$  units

(3)  $\frac{6}{\sqrt{3}}$  units

(4)  $\frac{8}{\sqrt{3}}$  units

- (ii) The equation of the perpendicular from the point  $(1, 0, 1)$  to the plane  $x - y + z = 4$  is [1]

(1)  $\frac{x-1}{2} = \frac{y+3}{-1} = \frac{z+5}{2}$

(2)  $\frac{x-1}{2} = \frac{y+3}{-1} = \frac{z-5}{2}$

(3)  $\frac{x-1}{1} = \frac{y}{-1} = \frac{z-1}{1}$

(4)  $\frac{x-1}{2} = \frac{y}{-2} = \frac{z-1}{1}$

@AAKASH\_TEST\_PAPERS\_2024

Corporate Office: Aakash Tower, 8, Pusa Road, New Delhi-110005. Ph.: 011-47623456  
(98)

## Model Test Paper-1

## Mathematics (Class XII)

(iii) The equation of the plane parallel to the plane  $x - y + z = 4$ , which is at a unit distance from the point  $(1, 0, 1)$  is [2]

(1)  $x - y + z = (2 - \sqrt{3})$

(2)  $x - y + z - (3 + \sqrt{3}) = 0$

(3)  $x - y + z = (2 + \sqrt{3})$

(4) Both (1) & (3)

37. A potter made a mud vessel, where the shape of the pot is based on  $f(x) = |x - 3| + |x - 2|$ , where  $f(x)$  represents the height of the pot.



(i) When  $x > 4$ , what will be the height in terms of  $x$ ? [2]

(1)  $x - 2$

(2)  $x - 3$

(3)  $2x - 5$

(4) Both (1) and (3)

(ii) Will the slope of  $f(x)$  vary with  $x$  value? [1]

1. Yes

2. No

(iii) What is  $\frac{df(x)}{dx}$  at  $x = 3$ ? [1]

(1) 2

(2) -2

(3) Function is not differentiable

(4) 1

@AAKASH\_TEST\_PAPERS\_2024

Corporate Office: Aakash Tower, 8, Pusa Road, New Delhi-110005. Ph.: 011-47623456  
(99)

## Mathematics (Class XII)

## Model Test Paper-1

38. Two groups are competing for the position on the Board of directors of a corporation. The probabilities that the first and the second groups will win are 0.6 and 0.4 respectively. Further, if the first group wins, the probability of introducing a new product is 0.7 and the corresponding probability is 0.3 if the second group wins.



Based on the given information, answer the following questions.

- (i) If new product is introduced then find probability that the new product is launched by first group. [2]
- (ii) If new product is introduced then find probability that the new product is launched by second group. [2]



@AAKASH\_TEST\_PAPERS\_2024

Corporate Office: Aakash Tower, 8, Pusa Road, New Delhi-110005. Ph.: 011-47623456  
(100)

## Model Test Paper-2

## Mathematics (Class XII)

Time : 3 Hours

**Model Test Paper-2**  
for  
**School/Board Exams**

M.M. : 80

**MATHEMATICS****Topics:** Complete Syllabus of Class XII**General Instructions:**

1. This question paper contains **five sections - A, B, C, D and E**. Each part is compulsory.
2. **Section - A** has 18 **MCQ's** and 02 Assertion-Reason based questions of 1 mark each.
3. **Section - B** has 5 **Very Short Answer (VSA)-type** questions of 2 marks each.
4. **Section - C** has 6 **Short Answer (SA)-type** questions of 3 marks each.
5. **Section - D** has 4 **Long Answer (LA)-type** questions of 5 marks each.
6. **Section - E** has 3 **source based/verse based/real life based/integrated units of assessment** (4 marks each) with sub parts.

**SECTION - A****(Multiple Choice Questions)****Each question carries 1 mark**

1. If  $A = \begin{pmatrix} 4 & x+2 \\ 2x-3 & x+1 \end{pmatrix}$  is symmetric matrix, then value of x is **[1]**  
(1) 2 (2) 3  
(3) -1 (4) 5
2. If the order of A is  $4 \times 3$ , the order of B is  $4 \times 5$  and the order of C is  $7 \times 3$ , then the order of  $(A^T B)^T C^T$  is **[1]**  
(1)  $5 \times 3$  (2)  $4 \times 5$   
(3)  $5 \times 7$  (4)  $4 \times 3$

@AAKASH\_TEST\_PAPERS\_2024

Corporate Office: Aakash Tower, 8, Pusa Road, New Delhi-110005. Ph.: 011-47623456  
(101)

## Mathematics (Class XII)

## Model Test Paper-2

3. Two unit vectors are inclined at an angle  $\theta$ , so that their resultant is also a unit vector. Then  $\theta$  is [1]
- (1)  $30^\circ$  (2)  $60^\circ$   
(3)  $120^\circ$  (4)  $150^\circ$
4. Function  $f(x) = \begin{cases} x+1, & x \geq 0 \\ k, & x < 0 \end{cases}$  will be continuous at  $x = 0$  then  $k$  is [1]
- (1) 2 (2) 0  
(3) -1 (4) 1
5. The solution of the differential equation  $\frac{dx}{dt} + kx^2 = 0$  is given by [1]
- (1)  $\frac{1}{x} = kt + C$  (2)  $\frac{1}{x} = -kt + C$   
(3)  $\frac{1}{t} = kx + C$  (4)  $\frac{1}{t} = -kx + C$
6. The order and degree of the differential equation  $4 \left( \frac{v}{dx} \right)^{2.3} = \frac{d^2y}{dx^2}$  are [1]
- (1) Order 2 and degree 2  
(2) Order 3 and degree 3  
(3) Order 2 and degree 3  
(4) Order 3 and degree 2
7. Variables used in the objective function while solving linear programming problems are known as \_\_\_\_\_ variables. [1]
- (1) Subjective (2) Accidental  
(3) Objective (4) Relational
8. Value of  $\sec^{-1}(2) + \operatorname{cosec}^{-1}(2) + \cos^{-1}(1)$  is [1]
- (1)  $\frac{\pi}{4}$  (2) 0  
(3)  $\pi$  (4)  $\frac{\pi}{2}$

## Model Test Paper-2

## Mathematics (Class XII)

9. The function  $f(x) = \tan^{-1}(\sin x - \cos x)$  is increasing if [1]

(1)  $x \in (0, \pi)$  (2)  $x \in \left(\frac{\pi}{2}, \pi\right)$

(3)  $x \in \left(0, \frac{3\pi}{4}\right)$  (4)  $x \in (0, 2\pi)$

10. If  $A = \begin{bmatrix} 1 & a & x \\ 0 & 1 & 0 \\ 0 & 0 & 1 \end{bmatrix}$  and  $B = \begin{bmatrix} 1 & -a & y \\ 0 & 1 & 0 \\ 0 & 0 & 1 \end{bmatrix}$  and  $AB = I_3$ , then value of  $x + y$  is

(where  $I_3$  is an Identity matrix of order 3) [1]

(1) 1 (2) 0

(3) -1 (4) 2

11. Consider the following LPP : [1]

Maximize  $z = 60X_1 + 50X_2$

Subject to  $X_1 + 2X_2 \leq 40$ ,  $3X_1 + 2X_2 \leq 60$ , where  $X_1$  and  $X_2 \geq 0$

(1) The LPP has a unique optimal solution

(2) The LPP is infeasible

(3) The LPP is unbound

(4) The LPP has multiple optimal solutions

12. If  $A = \begin{bmatrix} 1 & 0 & 0 \\ 0 & 1 & 0 \\ a & b & -1 \end{bmatrix}$ , then  $A^2 =$  [1]

(1) Unit matrix (2) Null matrix

(3) A (4) -A

13. If  $[2x \ 3] \begin{bmatrix} 1 & 2 \\ -3 & 0 \end{bmatrix} \begin{bmatrix} x \\ 8 \end{bmatrix} = 0$ , then the value of  $x$  is, ( $x \neq 0$ ) [1]

(1)  $\frac{23}{2}$  (2)  $\frac{13}{2}$

(3)  $-\frac{13}{2}$  (4)  $-\frac{23}{2}$

@AAKASH\_TEST\_PAPERS\_2024

Corporate Office: Aakash Tower, 8, Pusa Road, New Delhi-110005. Ph.: 011-47623456

(103)

## Mathematics (Class XII)

## Model Test Paper-2

14. If a coin is tossed thrice, find the probability of getting one or two heads. [1]

(1)  $\frac{4}{5}$

(2)  $\frac{5}{8}$

(3)  $\frac{3}{4}$

(4)  $\frac{6}{4}$

15. What is the solution of the differential equation  $\ln\left(\frac{dy}{dx}\right) - a = 0$ ? [1]

(1)  $y = xe^a + c$

(2)  $x = ye^a + c$

(3)  $y = \ln x + c$

(4)  $x = \ln y + c$

16. Find general solution of  $\left(xy \frac{dy}{dx} - 1\right) = 0$ . [1]

(1)  $xy = \log x + c$

(2)  $\frac{x^2}{2} = \log y + c$

(3)  $\frac{y^2}{2} = \log x + c$

(4) None of these

17. The value of the cross product  $(\vec{a} + \vec{b}) \times (\vec{a} + \vec{b})$  is [1]

(1)  $\vec{a}^2 - \vec{b}^2$

(2)  $2(\vec{a} \times \vec{b})$

(3)  $\vec{a} \times \vec{b}$

(4)  $\vec{b} \times \vec{a}$

18. Find the Cartesian equation of the plane which passes through the point  $(5, 2, -4)$  and perpendicular to the line with direction ratios  $2, 3, -1$ . [1]

(1)  $x + 2y - 3z = 18$

(2)  $2x + 3y - z = 20$

(3)  $2x + 3y - 5z = 24$

(4)  $2x + 5y - 7z = 15$

## ASSERTION-REASON BASED QUESTIONS

In the following questions, a statement of assertion (A) is followed by a statement of Reason (R). Choose the correct answer out of the following choices.

- (1) Both A and R are true and R is the correct explanation of A.
- (2) Both A and R are true but R is not the correct explanation of A.
- (3) A is true but R is false.
- (4) A is false but R is true.

@AAKASH\_TEST\_PAPERS\_2024

Corporate Office: Aakash Tower, 8, Pusa Road, New Delhi-110005. Ph.: 011-47623456

(104)

## Model Test Paper-2

## Mathematics (Class XII)

19. **Assertion (A)** : Principal value of  $\sin^{-1}\left(\frac{1}{\sqrt{2}}\right)$  is  $\frac{\pi}{4}$ . [1]

**Reason (R)** : Principal value of  $\cot^{-1}\left(\frac{-1}{\sqrt{3}}\right)$  is  $\frac{\pi}{3}$ .

20. **Assertion (A)** : The area of parallelogram with diagonals  $\vec{a}$  and  $\vec{b}$  is  $\frac{1}{2}|\vec{a} \times \vec{b}|$ . [1]

**Reason (R)** : If  $\vec{a}$  and  $\vec{b}$  represent the adjacent sides of a triangle, then this can be obtained by evaluating  $|\vec{a} \times \vec{b}|$ .

## SECTION - B

(This section comprises of very short answer type questions (VSA) of 2 marks each)

21. Write the value of  $\tan^{-1}(\sqrt{3})$ ,  $\cot^{-1}(\sqrt{3})$ . [2]

OR

If  $R = \{(x, y) : x + 2y = 8\}$  is a relation in  $N$ , write the range of  $R$ .

22. For the curve  $y = 5x - 2x^3$ ,  $x$  increases at the rate of 2 units/second, find the rate of change of the slope of the curve when  $x = 3$ . [2]

23. Find the unit vector in the direction of the sum of the vectors : [2]

$$\vec{a} = 2\hat{i} - \hat{j} + 2\hat{k} \text{ and } \vec{b} = -\hat{i} + \hat{j} + 3\hat{k}$$

OR

Find the vector equation of the line which passes through the point (3, 4, 5) and is parallel to the vector  $2\hat{i} + 2\hat{j} - 3\hat{k}$ .

24. If  $y = \sin^{-1}(6x\sqrt{1-9x^2})$ ,  $-\frac{1}{3\sqrt{2}} < x < \frac{1}{3\sqrt{2}}$ , then find  $\frac{dy}{dx}$ . [2]

25. Find the position vector of a point which divides the join of points with position vectors  $\vec{a} - 2\vec{b}$  and  $2\vec{a} + \vec{b}$  externally in the ratio 2 : 1. [2]

@AAKASH\_TEST\_PAPERS\_2024

## Mathematics (Class XII)

## Model Test Paper-2

## SECTION - C

(This section comprises of short answer type questions (SA)  
of 3 marks each)

26. Find  $\int \frac{\sin^2 x - \cos^2 x}{\sin x \cos x} dx$ . [3]

27. A bag contains 4 balls. Two balls are drawn at random without replacement and are found to be blue. What is the probability that all balls in the bag are blue? [3]

OR

In a neighbourhood, 90% children were falling sick due flu and 10% due to measles and no other disease. The probability of observing rashes for measles is 0.95 and for flu is 0.08. If a child develops rashes, find the child's probability of having flu.

28. Evaluate  $\int_0^{\pi/2} e^x (\sin x - \cos x) dx$ . [3]

OR

Evaluate  $\int_e^{e^2} \frac{dx}{x \log x}$ .

29. Solve the differential equation  $\frac{dy}{dx} + y \cot x = 2 \cos x$ , given that  $y = 0$ , when

$$x = \frac{\pi}{2}. \quad [3]$$

OR

Solve the differential equation :

$$(x^2 - yx^2)dy + (y^2 + x^2y^2)dx = 0, \text{ given that } y = 1, \text{ when } x = 1.$$

30. Minimize and maximize  $Z = 5x + 2y$  subject to the following constraints :  
 $x - 2y \leq 2, 3x + 2y < 12, -3x + 2y \leq 3, x \geq 0, y \geq 0$ . [3]

31. Evaluate  $\int \frac{\sin(x-a)}{\sin(x+a)} dx$ . [3]

@AAKASH\_TEST\_PAPERS\_2024

## Model Test Paper-2

## Mathematics (Class XII)

## SECTION - D

(This section comprises of long answer type questions (LA)  
of 5 marks each)

32. Using integration, find the area of  $\Delta ABC$ , the coordinates of whose vertices are  $A(2, 5)$ ,  $B(4, 7)$  and  $C(6, 2)$ . [5]
33. Let  $A = R - \{3\}$  and  $B = R - \{1\}$ . Consider the function  $f: A \rightarrow B$  defined by  $f(x) = \left(\frac{x-2}{x-3}\right)$ . Is  $f$  one-one and onto? Justify your answer. [5]

OR

Show that the relation  $S$  on the set:

$A = \{x \in \mathbb{Z} : 0 \leq x \leq 12\}$  given by  $S = \{(a, b) : a, b \in \mathbb{Z}, |a - b| \text{ is divisible by } 3\}$  is an equivalence relation.

34. Find the vector equation of the plane which contains the line of intersection of the planes

$$\vec{r} \cdot (\hat{i} + 2\hat{j} + 3\hat{k}) - 4 = 0,$$

$$\vec{r} \cdot (2\hat{i} + \hat{j} - \hat{k}) + 5 = 0$$

and which is perpendicular to the plane  $\vec{r} \cdot (5\hat{i} + 3\hat{j} - 6\hat{k}) + 8 = 0$  [5]

OR

Find the foot of the perpendicular from the point  $(1, 6, 3)$  to line  $\frac{x}{1} = \frac{y-1}{2} = \frac{z-2}{3}$ . Also, find the length of the perpendicular and the equation of the perpendicular.

35. If  $A = \begin{bmatrix} 1 & 0 & 2 \\ 0 & 2 & 1 \\ 2 & 0 & 3 \end{bmatrix}$ , show that  $A^2 - 6A + 7A + 2I = 0$  [5]

@AAKASH\_TEST\_PAPERS\_2024

Corporate Office: Aakash Tower, 8, Pusa Road, New Delhi-110005. Ph.: 011-47623456  
(107)

## SECTION - E

(This section comprises of 3 case study/passage-based questions of 4 marks each with two sub-parts. First two case study questions have three sub-parts (i), (ii), (iii) of marks 1, 1, 2 respectively. The third case study question has two sub-parts of 2 marks each)

36. An organization conducted bike race under 2 different categories-boys and girls. In total there were 250 participants. Among all of them finally three from Category 1 and two from Category 2 were selected for the final race. Ravi forms two sets  $B$  and  $G$  with these participants for his college project.



Let  $B = \{b_1, b_2, b_3\}$   $G = \{g_1, g_2\}$  where  $B$  represents the set of boys selected and  $G$  the set of girls who were selected for the final race.

Ravi decides to explore these sets for various types of relations and functions. [1]

- (i) Ravi wishes to form all the relations possible from  $B$  to  $G$ . How many such relations are possible?

- (1)  $2^6$  (2)  $2^5$   
(3) 0 (4)  $2^3$

- (ii). Let  $R: B \rightarrow B$  be defined by  $R = \{(x, y): x \text{ and } y \text{ are students of same sex}\}$ , Then this relation  $R$  is \_\_\_\_\_ [1]

- (1) Equivalence  
(2) Reflexive only  
(3) Reflexive and symmetric but not transitive  
(4) Reflexive and transitive but not symmetric

## Model Test Paper-2

## Mathematics (Class XII)

(iii) Ravi wants to know among those relations, how many functions can be formed from  $B$  to  $G$ ? [2]

(1)  $2^2$

(2)  $2^{12}$

(3)  $3^2$

(4)  $2^3$

37.

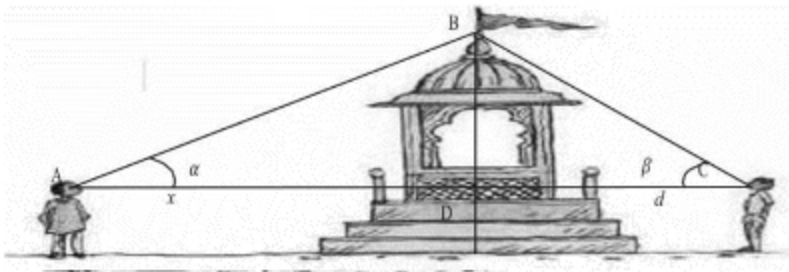

Two men on either side of a temple of 30 meters high observe its top at the angles of elevation  $\alpha$  and  $\beta$  respectively (as shown in the figure above). The distance between the two men is  $40\sqrt{3}$  meters and the distance between the first person and the temple is  $30\sqrt{3}$  meter.

Based on the above information answer the following:

(i)  $\angle BCA = \beta =$

[1]

(1)  $\tan^{-1}\left(\frac{1}{2}\right)$

(2)  $\tan^{-1}(2)$

(3)  $\tan^{-1}\left(\frac{1}{\sqrt{3}}\right)$

(4)  $\tan^{-1}(\sqrt{3})$

(ii)  $\angle ABC =$

[1]

(1)  $\frac{\pi}{4}$

(2)  $\frac{\pi}{6}$

(3)  $\frac{\pi}{2}$

(4)  $\frac{\pi}{3}$

@AAKASH\_TEST\_PAPERS\_2024

Corporate Office: Aakash Tower, 8, Pusa Road, New Delhi-110005. Ph.: 011-47623456  
(109)

## Mathematics (Class XII)

## Model Test Paper-2

(iii) Domain and Range of  $\cos^{-1} x$  are respectively [2]

(1)  $(-1, 1), (0, \pi)$

(2)  $[-1, 1], (0, \pi)$

(3)  $[-1, 1], [0, \pi]$

(4)  $(-1, 1), \left[-\frac{\pi}{2}, \frac{\pi}{2}\right]$

38. On her birthday, Seema decided to donate some money to children of an orphanage home. If there were 8 children less, everyone would have got ₹ 10 more. However, if there were 16 children more, everyone would have got ₹ 10 less. Let the number of children be  $x$  and the amount distributed by Seema for one child be  $y$  (in ₹).



(i) Which of the following matrix equations represent the information given above? [2]

(1)  $\begin{bmatrix} 5 & 4 \\ 5 & 8 \end{bmatrix} \begin{bmatrix} x \\ y \end{bmatrix} = \begin{bmatrix} 40 \\ -80 \end{bmatrix}$

(2)  $\begin{bmatrix} 5 & -4 \\ 5 & -8 \end{bmatrix} \begin{bmatrix} x \\ y \end{bmatrix} = \begin{bmatrix} 40 \\ 80 \end{bmatrix}$

(3)  $\begin{bmatrix} 5 & -4 \\ 5 & -8 \end{bmatrix} \begin{bmatrix} x \\ y \end{bmatrix} = \begin{bmatrix} 40 \\ -80 \end{bmatrix}$

(4)  $\begin{bmatrix} 5 & 4 \\ 5 & -8 \end{bmatrix} \begin{bmatrix} x \\ y \end{bmatrix} = \begin{bmatrix} 40 \\ -80 \end{bmatrix}$

(ii) The number of children who were given some money by Seema, is [2]

(1) 30

(2) 40

(3) 23

(4) 32



## Model Test Paper-3

## Mathematics (Class XII)

Time : 3 Hours

Model Test Paper-3  
for  
School/Board Exams

M.M. : 80

## MATHEMATICS

**Topics:** Complete Syllabus of Class XII**General Instructions:**

1. This question paper contains **five sections - A, B, C, D and E**. Each part is compulsory.
2. **Section - A** has 18 **MCQ's** and **02** Assertion-Reason based questions of 1 mark each.
3. **Section - B** has 5 **Very Short Answer (VSA)-type** questions of 2 marks each.
4. **Section - C** has 6 **Short Answer (SA)-type** questions of 3 marks each.
5. **Section - D** has 4 **Long Answer (LA)-type** questions of 5 marks each.
6. **Section - E** has 3 **source based/case based/passage based/integrated units of assessment** (4 marks each) with sub parts.

## SECTION - A

**(Multiple Choice Questions)****Each question carries 1 mark**

1. If  $A = \begin{bmatrix} 0 & 1 \\ 1 & 0 \end{bmatrix}$ , then the value of  $A^4$  is [1]

(1)  $\begin{bmatrix} 1 & 0 \\ 0 & 1 \end{bmatrix}$

(2)  $\begin{bmatrix} 1 & 1 \\ 0 & 0 \end{bmatrix}$

(3)  $\begin{bmatrix} 0 & 0 \\ 1 & 1 \end{bmatrix}$

(4)  $\begin{bmatrix} 0 & 1 \\ 1 & 0 \end{bmatrix}$

@AAKASH\_TEST\_PAPERS\_2024

Corporate Office : Aakash Tower, 8, Pusa Road, New Delhi-110005. Ph.: 011-47623456

(111)

## Mathematics (Class XII)

## Model Test Paper-3

2.  $A = \begin{bmatrix} 1 & -1 & 0 \\ 3 & 2 & -1 \end{bmatrix}$  and  $B = \begin{bmatrix} 1 \\ 3 \\ 5 \end{bmatrix}$ , find  $(AB)^T$  [1]

(1)  $\begin{bmatrix} -2 \\ 4 \end{bmatrix}$

(2)  $[-2 \quad 4]$

(3)  $\begin{bmatrix} 2 \\ -4 \end{bmatrix}$

(4)  $[-2 \quad -4]$

3. If  $\vec{a} = 2\hat{i} + 2\hat{j} + 3\hat{k}$ ,  $\vec{b} = -\hat{i} + 2\hat{j} + \hat{k}$  and  $\vec{c} = 3\hat{i} + \hat{j}$  are such that  $\vec{a} + \gamma\vec{b}$  is perpendicular to  $\vec{c}$ , then value of  $\gamma$  is [1]

(1) 3

(2) 0

(3) 4

(4) 8

4. The value of  $\lambda$  so that the function  $f$  defined by

$$f(x) = \begin{cases} \lambda x, & \text{if } x < \pi/2 \\ \cos 2x, & \text{if } x > \pi/2 \end{cases}$$
 is continuous at  $x = \frac{\pi}{2}$  is [1]

(1)  $-0.5$

(2)  $-\frac{0.5}{\pi}$

(3)  $-2\pi$

(4)  $-\frac{2}{\pi}$

5. What is the degree of the differential equation

$$y = x \left( \frac{dy}{dx} \right)^2 + \left( \frac{dx}{dy} \right) ?$$
 [1]

(1) 1

(2) 2

(3) 3

(4) 4

6. The solution of the differential equation  $dy = (1 + y^2)dx$  is [1]

(1)  $y = \tan x + c$

(2)  $y = \tan(x + c)$

(3)  $\tan^{-1}(y + c) = x$

(4)  $\tan^{-1}(y + c) = 2x$

## Model Test Paper-3

## Mathematics (Class XII)

7. The value of  $\int_{-3}^3 (x^3 + \sin x) dx$  is equal to [1]

(1) 0

(2)  $\frac{\pi}{2}$

(3)  $\pi$

(4) 1

8. The feasible region for an LPP is shown shaded in the figure. Let  $z = 2x + 4y$  be the objective function. A minimum of  $z$  occurs at [1]

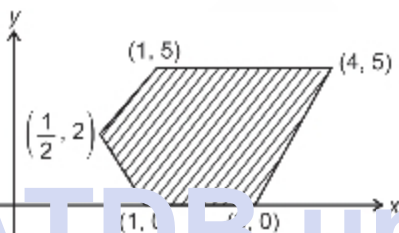

(1)  $\left(\frac{1}{2}, 2\right)$

(2) (1, 5)

(3) (1, 0)

(4) (3, 0)

9. Principal value of  $\sec^{-1}(-2)$  is [1]

(1)  $\frac{2\pi}{3}$

(2)  $\frac{-\pi}{3}$

(3)  $\frac{5\pi}{6}$

(4)  $\frac{-\pi}{6}$

@AAKASH\_TEST\_PAPERS\_2024

Corporate Office : Aakash Tower, 8, Pusa Road, New Delhi-110005. Ph.: 011-47623456

(113)

## Mathematics (Class XII)

## Model Test Paper-3

10. Cofactor of 11 in matrix  $A = \begin{bmatrix} 1 & 5 & 7 \\ 8 & 9 & 11 \\ 3 & 4 & 7 \end{bmatrix}$  is [1]

- (1) -11
- (2) -10
- (3) 10
- (4) 11

11. In a Linear Programming Problem, the linear relations of the variables which are either to be maximized or minimized is called \_\_\_\_\_. [1]

- (1) The decisions variables
- (2) The constraints functions
- (3) The variable function
- (4) The objective function

12. If  $A$  is a square matrix such that  $A^2 = I$  where  $I$  is a unit matrix of same order, then  $(I - A)(I + A)$  is [1]

- (1)  $A$
- (2)  $I$
- (3)  $2A$
- (4) Zero matrix

13. A square matrix  $A$  is called symmetric matrix if \_\_\_\_\_ where  $A'$  is the transpose of  $A$ . [1]

- (1)  $A' = 0$
- (2)  $A' = A$
- (3)  $A' = A^{-1}$
- (4)  $A' = -A$

14.  $A$  and  $B$  are two events such that  $P(B) = 0.4$  and  $P(A \cup B) = 0.6$  If  $A$  and  $B$  are independent, then  $P(A)$  is [1]

- (1)  $\frac{1}{2}$
- (2)  $\frac{1}{3}$
- (3)  $\frac{2}{3}$
- (4)  $\frac{2}{5}$

@AAKASH\_TEST\_PAPERS\_2024

Corporate Office : Aakash Tower, 8, Pusa Road, New Delhi-110005. Ph.: 011-47623456

## Model Test Paper-3

## Mathematics (Class XII)

15. What is the order of the differential equation  $y = x \frac{dy}{dx} + \left(\frac{dy}{dx}\right)^{-2}$ ? [1]
- (1) 1 (2) 3  
(3) 2 (4) 4
16. The solution of differential equation  $dy = (\cos^2 y)dx$  is [1]
- (1)  $y = \tan x^2 + c$  (2)  $\tan y = x + c$   
(3)  $y = \tan x + c$  (4)  $\tan y = x^2 + c$
17. For the vector  $\vec{a}$  with initial point  $P(4, 0, 2)$  and the terminal point  $Q(6, -1, 2)$ , the value of  $|\vec{a}|$  will be: [1]
- (1)  $\sqrt{3}$  (2)  $\sqrt{7}$   
(3)  $\sqrt{5}$  (4)  $\sqrt{2}$
18. The vector equation of the line passing through the points  $(-1, 0, 2)$  and  $(3, 4, 6)$  is [1]
- (1)  $\vec{r} = -2\hat{i} + \hat{k} + \lambda(4\hat{i} + 4\hat{j} + 4\hat{k})$  (2)  $\vec{r} = -\hat{i} + 2\hat{k} + \lambda(4\hat{i} - 4\hat{j} - 4\hat{k})$   
(3)  $\vec{r} = \hat{i} + 2\hat{k} - \lambda(4\hat{i} + 4\hat{j} + 4\hat{k})$  (4)  $\vec{r} = -\hat{i} + 2\hat{k} + \lambda(4\hat{i} + 4\hat{j} + 4\hat{k})$

## ASSERTION-REASON BASED QUESTIONS

In the following questions, a statement of assertion (A) is followed by a statement of Reason (R). Choose the correct answer out of the following choices.

- (1) Both A and R are true and R is the correct explanation of A.  
(2) Both A and R are true but R is not the correct explanation of A.  
(3) A is true but R is false.  
(4) A is false but R is true.
19. **Assertion (A)** : Range of  $\tan^{-1}x$  is  $\left(\frac{-\pi}{2}, \frac{\pi}{2}\right)$ . [1]

**Reason (R)** : Domain of  $\tan^{-1}x$  is  $R$ .

@AAKASH\_TEST\_PAPERS\_2024

Corporate Office : Aakash Tower, 8, Pusa Road, New Delhi-110005. Ph.: 011-47623456

(115)

## Mathematics (Class XII)

## Model Test Paper-3

20. **Assertion (A)** : The direction cosines of vector [1]

$$\vec{A} = 2\hat{i} + 4\hat{j} - 5\hat{k} \text{ are } \frac{2}{\sqrt{45}}, \frac{4}{\sqrt{45}}, -\frac{5}{\sqrt{45}}.$$

**Reason (R)** : A vector having zero magnitude and arbitrary direction is called 'zero vector' or 'null vector'.

## SECTION - B

(This section comprises of very short answer type questions (VSA) of 2 marks each)

21. If  $\sin\left(\sin^{-1}\frac{1}{5} + \cos^{-1}x\right) = 1$ , then find the value of  $x$ . (Where  $\sin^{-1}x + \cos^{-1}x = \frac{\pi}{2}$  for  $x \in [-1, 1]$ .) [2]

Show that a one-one function:  $f: \{1, 2, 3\} \rightarrow \{1, 2, 3\}$  must be onto.

22. Without using the derivative, show that the function  $f(x) = 7x - 3$  is a strictly increasing function in  $R$ . [2]
23. If  $\vec{a}$  and  $\vec{b}$  are perpendicular vectors,  $|\vec{a} + \vec{b}| = 13$  and  $|\vec{a}| = 5$ , find the value of  $|\vec{b}|$  [2]

OR

A line passes through the point with position vector  $2\hat{i} - \hat{j} + 4\hat{k}$  and is in the direction of the vector  $\hat{i} + \hat{j} - 2\hat{k}$ . Find the equation of the line in vector and Cartesian form.

24. Differentiate  $\log(1 + \theta)$  w.r.t.  $\sin^{-1}\theta$ . [2]

@AAKASH\_TEST\_PAPERS\_2024

Corporate Office : Aakash Tower, 8, Pusa Road, New Delhi-110005. Ph.: 011-47623456

(116)

## Model Test Paper-3

## Mathematics (Class XII)

25. Write the direction ratios of the vector  $3\vec{a} + 2\vec{b}$ , where  $\vec{a} = \hat{i} + \hat{j} - 2\hat{k}$  and  $\vec{b} = 2\hat{i} - 4\hat{j} + 5\hat{k}$ . [2]

## SECTION - C

(This section comprises of short answer type questions (SA)  
of 3 marks each)

26. Find  $\int \frac{\sin^2 x - \cos^2 x}{\sin^2 x \cos^2 x} dx$ . [3]
27. There are three identical cards except that both the sides of the first card is coloured red, both sides of the second card is coloured blue and for the third card one side is coloured red and the other side is blue. One card is randomly selected among these three cards and put down, visible side of the card is red. What is the probability that the other side is blue? [3]

OR

These are three urns containing white and black balls. First urn has 3 white and 2 black balls, second urn has 2 white and 3 black balls and third urn has 4 white and 1 black balls. Without any biasing one urn is chosen from that one ball is chosen randomly which was white. What is probability that it came from the third urn?

28. Evaluate  $\int_2^3 \frac{1}{x} dx$  [3]

OR

Evaluate  $\int_0^2 \sqrt{4-x^2} dx$ .

29. Find the general solution of the differential equation  $(1 - y^2)(1 + \log x)dx + 2xydy = 0$  given that  $y = 0$  when  $x = 1$ . [3]

OR

Find the general solution of the differential equation  $ydx - (x + 2y^2)dy = 0$ .

@AAKASH\_TEST\_PAPERS\_2024

## Mathematics (Class XII)

## Model Test Paper-3

30. Solve the following linear programming problem graphically: [3]

Maximize  $Z = 60x + 15y$  subject to the constraints

$$x + y \leq 50$$

$$3x + y \leq 90$$

$$x, y \geq 0$$

31. Evaluate  $\int \frac{x^2}{(x^2 + 4)(x^2 + 9)} dx$ . [3]

## SECTION - D

(This section comprises of long answer type questions (LA) of 5 marks each)

32. Make a rough sketch of the graph of the curve  $y = 2\sqrt{9 - x^2}$  and determine the area enclosed between the curve and x-axis. [5]

33. Let  $f : A \rightarrow B$  be a function defined as  $f(x) = \frac{2x+3}{x-3}$  where  $A = R - \{3\}$  and  $B = R - \{2\}$ . Is the function  $f$  one-one and onto? [5]

OR

Let  $A = \{1, 2, 3, \dots, 9\}$  and  $R$  be the relation in  $A \times A$  defined by  $(a, b) R (c, d)$  if  $a + d = b + c$  for  $(a, b), (c, d)$  in  $A \times A$ .

Prove that  $R$  is an equivalence relation. Also obtain the equivalence class  $\{(2, 5)\}$ .

34. Let  $L_1 : \vec{r}_1 = (\hat{i} + \hat{j} + \hat{k}) + \lambda(2\hat{i} - \hat{j} + \hat{k})$  and  $L_2 : \vec{r}_2 = (\hat{i} + \hat{j} + \hat{k}) + \mu(\hat{i} + \hat{j} - \hat{k})$  be two intersecting lines, then find the angle between  $L_1$  and  $L_2$  and also find Cartesian form of lines  $L_1$  and  $L_2$ . [5]

OR

Find the vector equation of a line passing through the point  $(2, 3, 2)$  and parallel to the line:

$$\vec{r} = (-2\hat{i} + 3\hat{j}) + \lambda(2\hat{i} - 3\hat{j} + 6\hat{k})$$

Also, find the distance between these two lines.

@Aakash\_Test\_Papers\_2024

Corporate Office : Aakash Tower, 8, Pusa Road, New Delhi-110005. Ph.: 011-47623456

## Model Test Paper-3

## Mathematics (Class XII)

35. Three schools A, B and C organized a mela for collecting funds for helping the rehabilitation of flood victims. They sold handmade fans, mats and plates from recycled material at a cost of ₹ 25, ₹ 100 and ₹ 50 each respectively. The number of articles sold are given below:

School \ Articles	A	B	C
Handmade fans	40	50	20
Mats	25	40	30
Plates	35	50	40

Find the funds collected by each school separately by selling the above articles. Also, find the total amount collected for the purpose. [5]

## SECTION - E

(This section comprises of 3 case study/passage-based questions of 4 marks each with two sub-parts. First two case study questions have three sub-parts (i), (ii) and (iii) of marks 1, 1, 2 respectively. The third case study question has two sub-parts of 2 marks each)

36. Students of Grade 9, planned to plant saplings along straight lines, which are parallel or perpendicular to the line  $y = x - 4$  ensuring that they had enough play area. Let  $L$  be the set of all lines which are on the ground and  $R$  be a relation on  $L$ .



Answer the following using the above information.

@AAKASH\_TEST\_PAPERS\_2024

Corporate Office : Aakash Tower, 8, Pusa Road, New Delhi-110005. Ph.: 011-47623456

(119)

## Mathematics (Class XII)

## Model Test Paper-3

- (i) Let  $R = \{(L1, L2) : L1 \perp L2 \text{ where } L1, L2 \in L\}$  which of the following is true? [1]
- (1)  $R$  is symmetric but neither reflexive nor transitive
  - (2)  $R$  is reflexive and transitive but not symmetric
  - (3)  $R$  is reflexive but neither symmetric nor transitive
  - (4)  $R$  is an equivalence relation
- (ii) The function  $f : R \rightarrow R$  defined by  $f(x) = x - 4$  is \_\_\_\_\_ [1]
- (1) Bijective
  - (2) Surjective but not injective
  - (3) Injective but not surjective
  - (4) Neither surjective nor injective
- (iii) Let  $f : R \rightarrow R$  be defined by  $f(x) = x - 4$ . Then the range of  $f(x)$  is \_\_\_\_\_ [2]
- (1)  $R$
  - (2)  $Z$
  - (3)  $W$
  - (4)  $Q$

37. A manufacture produces three stationary products –Pencil, Eraser and Sharpener which he sells in two markets. Annual sales are indicated below:



@AAKASH\_TEST\_PAPERS\_2024

Corporate Office : Aakash Tower, 8, Pusa Road, New Delhi-110005. Ph.: 011-47623456

(120)

## Model Test Paper-3

## Mathematics (Class XII)

Market	Products (in numbers)		
	Pencil	Eraser	Sharpener
A	10,000	2,000	18,000
B	6000	20,000	8,000

If the unit sale prices of Pencil, Eraser and Sharpener are ₹ 2.50, ₹ 1.50 and ₹ 1.00 respectively, and unit cost of the above three commodities are ₹ 2.00, ₹ 1.00 and ₹. 0.50 respectively, then,

Based on the above information answer the following:

(i) Total revenue of market A is [1]

- (1) ₹ 64,000 (2) ₹ 60,400  
(3) ₹ 46,000 (4) ₹ 40,600

(ii) Total revenue of market B is [1]

- (1) ₹ 15,000 (2) ₹ 13,000  
(3) ₹ 50,300 (4) ₹ 60,000

(iii) Total revenue of both markets is [2]

- (1) ₹ 13,000 (2) ₹ 30,100  
(3) ₹ 10,300 (4) ₹ 99,000

38. Two farmers Ramakishan and Gurucharan Singh cultivate only three varieties of rice namely Basmati, Permal and Naura. The sale (in Rupees) of these varieties of rice by both the farmers in the month of September and October are given by the following matrices A and B.



## Mathematics (Class XII)

## Model Test Paper-3

September sales (in Rupees)

$$A = \begin{bmatrix} 10,000 & 20,000 & 30,000 \\ 50,000 & 30,000 & 10,000 \end{bmatrix} \begin{matrix} \text{Ramakishan} \\ \text{Gurucharan} \end{matrix}$$

October sales (in Rupees)

$$B = \begin{bmatrix} 5,000 & 10,000 & 6,000 \\ 20,000 & 10,000 & 10,000 \end{bmatrix} \begin{matrix} \text{Ramakishan} \\ \text{Gurucharan} \end{matrix}$$

- (i) What is the value of  $A_{23}$ ? [2]
- (1) 10000  
(2) 20000  
(3) 30000  
(4) 40000
- (ii) The decrease in sales from September to October is given by [2]
- (1)  $A > B$   
(2)  $A < B$   
(3)  $A > B$   
(4)  $A < B$

□ □ □

@AAKASH\_TEST\_PAPERS\_2024

Corporate Office : Aakash Tower, 8, Pusa Road, New Delhi-110005. Ph.: 011-47623456

(122)



# CBSE Class XII Board Exam Result 2023

## Top Performers from Classroom Programs

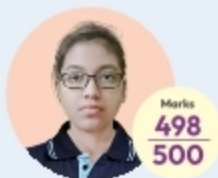

Pratistha Pal



Kabir

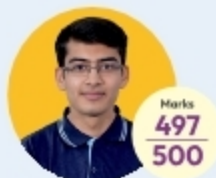

Dhruv Advani



Aadya Roy



Samrudhi Pravin S



Soumil Kaul



Aaron B Manjooran

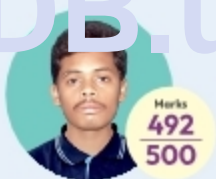

Alex Singh

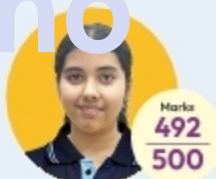

Sneha Ray



Vijay Kulkarni

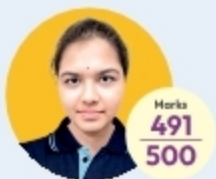

Sravani Reddy



Sagnik Debnath

and many more...

Scan the QR Code for Nearest Branch



Download Aakash App



CALL (TOLL-FREE)

1800-102-2727

VISIT

[akash.ac.in](http://akash.ac.in)

